

# DVP-SC

## Logic Controller with Special Pulse Input/Output Function Instruction Sheet

### 1 WARNING

This Instruction Sheet only provides descriptions for electrical specifications, general specifications, installation & wiring, troubleshooting and peripherals. Other detail information about programming and instructions is compatible with SA/SX/SC series; please see PLC Application Manual. For more information about the optional peripherals, please see individual product instruction sheet.

This is an OPEN TYPE PLC. The PLC should be kept in an enclosure away from airborne dust, humidity, electric shock risk and vibration. Also, it is equipped with protective methods such as some special tools or keys to open the enclosure, in order to prevent hazard to users or damage the PLC.

Do NOT connect the AC main circuit power supply to any of the input/output terminals, or it may damage the PLC. Check all the wiring prior to power up. To prevent any electromagnetic noise, make sure the PLC is properly grounded. Do NOT touch terminals when power on.

Battery replacement: please use UL component type: TDRTL-2150/S lithium battery which battery life.

### 2 INTRODUCTION

Thank you for choosing DELTA's PLC DVP series. The DVP-SC series has a 12-points (8 input points + 4 outputs) MPU with powerful instructions (the same instruction sets as SA/SX/SC series) for use. It also has an 8K Steps program memory and high-speed pulse inputs(X10 and X11)/outputs (Y10 and Y11). For high-speed pulse, total bandwidth can up to 130KHz and 100KHz maximum for single input/output. Besides, it also provides instructions of position control and zero point return to use with high-speed pulse output. It could connect all extension units of DVP-SS series for various applications.

#### 2.1 Product Profile and Outline

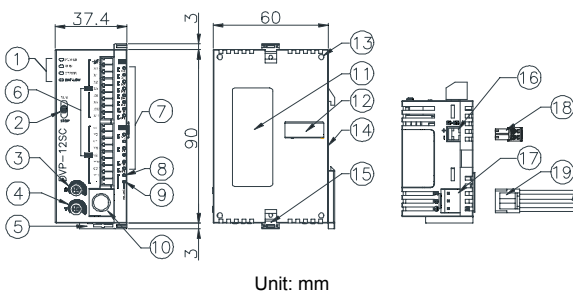

- 1 Status indicators of POWER, RUN and ERROR
- 2 RUN/STOP switch
- 3 VR0: Start-up by M1178/D1178 Corresponding value
- 4 VR1: Start-up by M1179/D1179 Corresponding value
- 5 DIN rail clip
- 6 I/O terminals
- 7 I/O point indicators
- 8 COM1 (RS-232) (Rx) indicator
- 9 COM2 (RS-485) (Tx) indicator
- 10 COM1 (RS-232) port
- 11 Nameplate
- 12 Extension port for wire to connect extension module/unit
- 13 Mounting hole
- 14 DIN rail track (35mm)
- 15 Extension unit clip
- 16 RS-485 communication port (Master/Slave)
- 17 DC Power input
- 18 2 pin removable terminal (standard accessory)
- 19 Power input cable (standard accessory)
- 20 Battery cover
- 21 Battery socket connection
- 22 Battery holder

Battery replacement: Battery replacement must be finished within 3 minutes, or the internal data of the PLC (including the program area, RTC and latched registers) could be lost or destroyed.

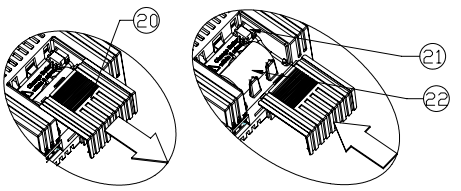

#### 2.2 Model Name Explanation and Peripherals

■ Nameplate

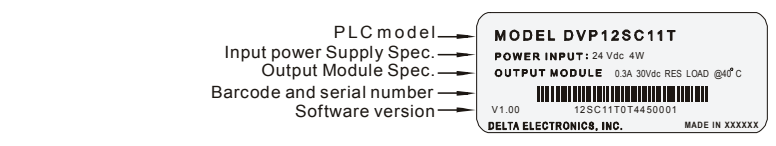

PLC model: MODEL DVP12SC11T  
 Input power Supply Spec. POWER INPUT : 24 Vdc 4W  
 Output Module Spec. OUTPUT MODULE 0.3A 30Vdc RES LOAD @40°C  
 Barcode and serial number  
 Software version V1.00 12SC11T014450001  
 DELTA ELECTRONICS, INC. MADE IN CHINA

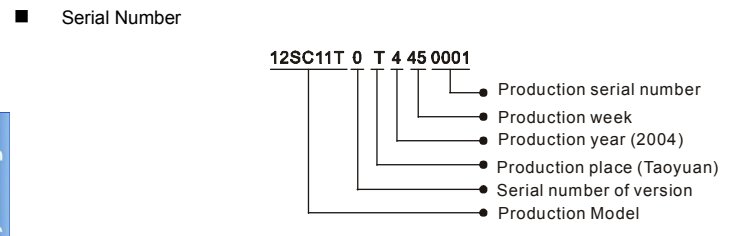
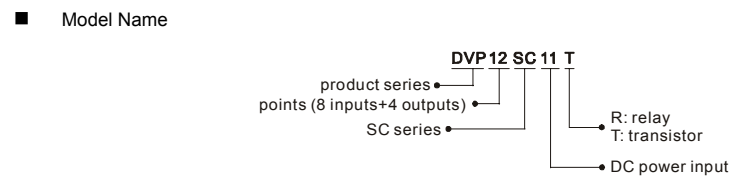

- Peripherals
- DVPHPP02: Handheld Programming panel
  - WPLSoft: Windows Ladder Logic Programming Software
  - DVPACAB115: 1.5M Cable (HPP ↔ PLC, packaged with DVPHPP02)
  - DVPACAB215: 1.5M Cable (PC (DB9+DB25) ↔ PLC)
  - DVPACAB230: 3.0M Cable (PC (DB9+DB25) ↔ PLC)
  - DVPACAB2A30: 3.0M Cable (PC (DB9) ↔ PLC)

### 3 FUNCTION SPECIFICATIONS

Items	Specifications	Remarks
Control Method	Stored program, cyclic scan system	
I/O Processing Method	Batch processing method (when END instruction is executed)	I/O refresh instruction is available
Execution Speed	Basic instructions (several us)	Application instructions (10~hundreds us)
Program language	Instructions + Ladder Logic + SFC	Including the Step instructions
Program Capacity	7920 STEPS	SRAM+ Battery
Instructions	32 Basic sequential instructions (including step instructions)	168 Application instructions
X External input relay	X0~X177 in octal, 128 points in decimal	Total 256 points Correspond to external input point
	Y External output relay	Y0~Y177 in octal, 128 points in decimal Correspond to external output point
M Auxiliary Relay	General	M0~M511, 512 points
	Latched	M512~M999, 488 points
	Special	M2000~M4095, 2096 points M1000~M1999, 1000 points (some are latched)
T Timer	100ms	T0~T199, 200 points
	10ms	T192~T199 for Subroutine T250~T255, 6 points Accumulative
	1ms	T200~T239, 40 points T240~T245, 6 points Accumulative
		T246~T249, 4 points Accumulative
C Counter	16-bit count up	C0~C95, 96 points
	32-bit count up/down	C96~C199, 104 points C200~C215, 16 points C216~C234, 19 points
	32bit high-speed count up/down	C235~C244, 1-phase 1 input, 9 inputs C243, C245, 1-phase 1 input, 2 points C246~C249, 1-phase 2 inputs, 3 points C250, 1-phase 2 inputs, 1 point C251~C254, 2-phase 2 inputs, 3 points
	Initial step point	S0~S9, 10 points
	Zero point return	S10~S19, 10 points, (use with IST instruction)
	General	S20~S511, 492 points
S Step point	Latched	S512~S895, 384 points
	Alarm	S896~S1023, 128 points
T Current value of the timer	T0~T255, 256 points	When the timer reaches the preset value, the contact of timer will be On.
C Current value of the counter	C0~C199, 16-bit counter, 200 points	When the counter reaches the preset value, the contact of counter will be On.
	C200~C254, 32-bit counter, 50 points	
D Data register	General	D0~D199, 200 points
	Latched	D200~D999, 800 points
	Special	D2000~D4999, 3000 points
	Index	D1000~D1999, 1000 points
None File register	E0~E3, F0~F3, 8 points	Total 5000 points Can be memory area for storing data. E and F can be used as the special purpose of index indication.
	0~1599(1600 points)	Extension register to store data.

efesotomasyon.com

Items	Specifications	Remarks	
N For master control nested loop	N0~N7, 8 points	Control point of master control nested loop	
	P For CJ. CALL instructions	P0~P255, 256 points	The location point of CJ, CALL.
I Interrupt Service	External interrupt	I001 (X0), I101 (X1), I201 (X2), I301 (X3), I401 (X4), I501 (X5); 6 points (all are rising-edge trigger)	The location pointer of interrupt subroutine
	Time interrupt	I6 (1ms), I7 (1ms), (01~99ms)	
	High-speed counter	I010, I020, I030, I040, I050, I060, 6 points	
	Communication	I150, 1 point	
Communication port in series (program read/write)	COM1: only for slave, ASCII/RTU are available, 115200 bps max. COM2: can be Master/Slave, ASCII/RTU are available, 115200 bps max. COM1and COM2 can be used simultaneously		
Potentiometer / RTC	MPU built-in 2 points VR / MPU built-in RTC		
High-speed Counter	1-phase 1 input: inputs X10(C243) and X11(C245). Input frequency can up to 100KHz. 1-phase 2 inputs: inputs (X10, X11) C250. Input frequency can up to 100KHz.		
Position Control	High-speed pulse outputs Y10 and Y11. Output frequency can up to 100KHz. It can be used as position control of servo drive or step drive when using with position instructions (DDRV1 and DDRVA) and DZRN (zero point return).		

#### PLC Latched Memory Settings for SC Models

M Auxiliary Relay	General	Latched	Special auxiliary relay	Latched	
	M0~M511	M512~M999	M1000~M1999	M2000~M4095	
T Timer	100 ms	10 ms	10ms	1 ms, 100 ms	
	T0 ~T199	T200~T239	T240~T245	T246~T249, T250~T255	
C Counter	16-bit count up		32-bit count up/down		
	C0~C95	C96~C199	C200~C215	C216~C234, C235~C245, C246~C255	
	Non-latched (fixed)	Latched (default)	Non-latched (fixed)	Latched (default)	Latched (default)
		Start: D1208 (K96) End: D1209 (K199)	Start: D1210 (K216) End: D1211 (K234)	Start: D1212 (K235) End: D1213 (K255)	
	S Step Relay	For general	Latched	Special register	Latched
S0~S9		S10~S19	S20~S511	S512~S895	
D Register	General		Latched	Special registers	
	D0~D199		D200~D999	D1000~D1999, D2000~D4999	
	Non-latched (fixed)	Factory setting is latched.		Some are latched and can't be changed.	
		Start: D1216 (K200) End: D1217 (K999)	Start: D1214 (K512) End: D1215 (K895)		
File Register	K0~K1599 Latched (fixed)				

When switching between power On/Off or MPU RUN/STOP modes:

Memory Type	POWER Off→On	STOP→RUN	RUN→STOP	Clear all M1031 non-latched area	Clear all M1032 latched area	Factory Setting
Non-latched	Clear	Unchanged	M1033=Off, clear	Clear	Unchanged	0
			M1033=On, unchanged			
Latched	Unchanged	Unchanged	Unchanged	Clear	0	
Special M, Special D, Index register	Initial value	Unchanged	Unchanged	Unchanged	Initial value	
File register	Unchanged					0

### 4 ELECTRICAL SPECIFICATIONS

Item	Model	DVP12SC11T
Power supply voltage		MPU: 24VDC (-15%~+20%) (With DC input reverse polarity protection), Extension Unit: supplied by the MPU
Fuse		2A
Power Consumption		4W MAX
Insulation Resistance		5 MΩ and above at 500 VDC (Between all inputs / outputs and earth)
Noise Immunity		ESD: 8KV Air Discharge EFT: Power Line: 2KV, Digital I/O: 1KV, Analog & Communication I/O: 250V Damped-Oscillatory Wave: Power Line: 1KV, Digital I/O: 1KV RS: 26MHz~1GHz, 10V/m
Grounding		The diameter of grounding wire cannot be smaller than the wire diameter of terminals L and N (All DVP units should be grounded directly to the ground pole).
Environment		Operation: 0°C~55°C (Temperature), 50~95% (Humidity), Pollution degree 2; Storage: -25°C~70°C (Temperature), 5~95% (Humidity)
Vibration / Shock Resistance		Standard: IEC1131-2, IEC 68-2-6 (TEST Fc) / IEC1131-2 & IEC 68-2-27 (TEST Ea)
Weight (approx.) (g)		158

efesotomasyon.com

Approvals			
Input Specifications		Output Specifications	
Input Type	Photo coupler Isolation	Output Type	Transistor
Input Current	24VDC 5mA	Rated current	0.3A/1 point @ 40°C (Room Temp.)
Switching Voltage	Off→On, 16VDC and above	Voltage Specification	5-30VDC
	On→Off, below 14.4VDC	Max. Inductive load	7.2W/24V
Response Time	X0~X5	Output protection	Internal: None Outside: Rated value according to the load
	X10, X11	Maximum Loading	Y0, Y1: 9W / 1 point Y10, Y11: 0.9W / 1 point
		Response Time	Off→On: <20us <1us (Y10, Y11 only) On→Off: <30us <1us (Y10, Y11 only)

**5 MODEL NAME & I/O CONFIGURATION**

Model	Power	Input/Output Specification				I/O Configuration
		Input Unit		Output Unit		
		Points	Type	Points	Type	
DVP12SC11T	24VDC	6	24VDC Sink/Source X0~X5	2	Transistor Y0, Y1	
		2	24VDC Sink/Source Hi-speed X10, X11	2	Transistor Hi-speed Y10, Y11	

**6 INSTALLATION & WIRING**

**6.1 PLC Mounting Arrangements and Wiring Notes**

- When installing the DVP series PLC, make sure that it is installed in an enclosure with sufficient space (as shown on the right) to its surroundings so as to allow heat dissipation.
- I/O signal wires or power supply should not run through the same multi-wire cable or conduit.
- Please use 22-16AWG (1.5mm) wiring (either single or multiple core) for I/O wiring terminals. The specification for the terminals is as shown on the right.
- PLC terminal screws should be tightened to a torque of 1.95 kg-cm (1.7 in-lbs). Use Copper Conductor Only, 60/75 °C

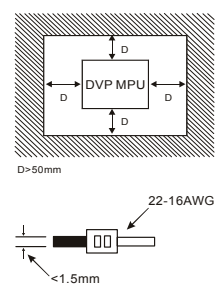

**6.2 Wiring Notes**

DVP-SC Series input power supply is DC input. Please take a note of listed items when operating DVP-SC Series.

**Input/Output Wiring**

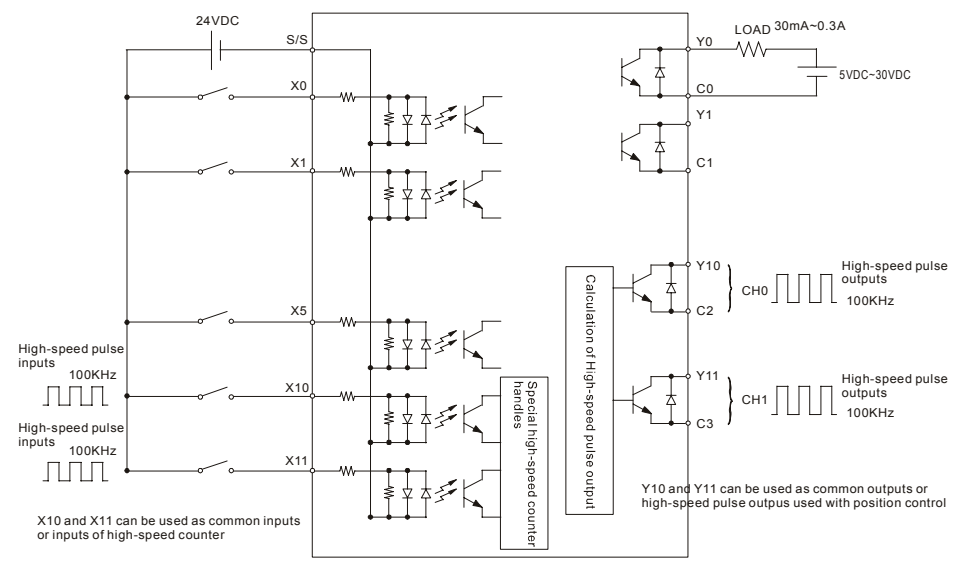

**Power Input Wiring**

- Please make sure the power is at terminals 24VDC and 0V (power range is 20.4VDC~28.8VDC). When voltage is lower than 20.4VDC, PLC will stop operating, all outputs will be Off and ERROR LED will flash continuously.
- If the power-cut time is less than 10ms, the PLC still operates unaffectedly. If the power-cut time is too long or

the power voltage drops, the PLC will stop operating and all the outputs will be Off. Once the power is restored, the PLC will return to operation automatically.

**Safety Wiring**

Since the PLC is used to control numerous devices, motion of either one device could affect the motion of other devices. Therefore the breakdown of a device would consequently be detrimental to the whole auto control system, thus the result is dangerous. Please use the recommended wiring below for the power input (DVPPS01/DVPPS02):

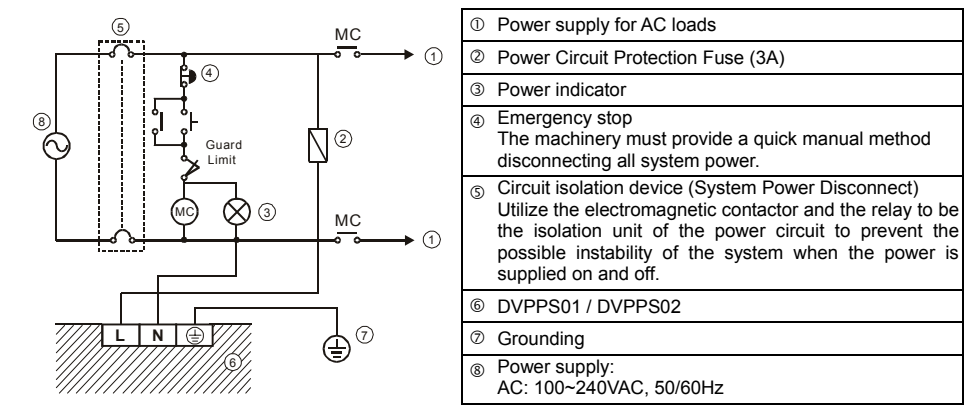

**7 HIGH-SPEED PULSE INPUT FUNCTION**

**Additional high-speed input counters of DVP-SC series**

Additional number and function table

	1-phase 1 input										1-phase 2 inputs			A/B phase input					
	C235	C236	C237	C238	C239	C240	C241	C242	C243	C244	C245	C246	C247	C249	C250	C251	C252	C254	C255
X0	U/D						U/R				U/D	U	U	U		A	A	A	
X1		U/D					R				R	D	D	D		B	B	B	
X2			U/D					U/D				R	R	R		R	R	R	
X3				U/D			R		S					S				S	
X4					U/D														
X5						U/D													
X10								U/D							U				A
X11										U/D					D				B

Additional high-speed counters C243, C245, C250 and C255 correspond to count input X10 and X11. The counters correspond to X0~X5 are the same as SA/SX series.

**8 TRIAL RUN**

**Power Indicator**

The "POWER" LED at the front of the MPU or the Extension Units will be lit (in green) if the power is on. If the indicator is not ON or ERROR LED is blinking swiftly when the MPU is powered up, it means that the +24V power supply of the PLC is insufficient, i.e. the 24V DC power supply of the PLC is overloaded. It is thus necessary to remove the wiring on terminals +24V and 24G, and to use a 24VDC power supply instead.

**Low Battery Voltage Indicator**

There is also a "BAT.LOW" LED at the front of the MPU. When the LED is on, it indicates that the battery voltage is not enough. Please change the batter (within 3 minutes) as soon as possible; otherwise the user programs and the data in latched area may be lost.

**Preparation**

- Prior to applying power, please verify that the power lines and the input/output wiring are correct. And be advised not to supply AC110V or AC220V into the I/O terminals, or it might short-circuit the wiring and would cause direct damage to the PLC.
- After using the peripheral devices to write the program into the MPU and that the ERROR LED of the MPU is not on, it means that the program in use is legitimate, and it is now waiting for the user to give the RUN instruction.
- Use HPP to execute the forced On/Off test of the output contact.

**Operation & Test**

If the "ERROR" LED of the MPU is not blinking, use RUN/STOP switch or the peripheral devices (HPP or WPLSoft) to give the RUN instruction, and the RUN indicator will then be on. If the "RUN" LED is not on, it indicates that there is no program inside the PLC. HPP could be utilized to monitor the settings and the registered values of the timer (T), the counter (C) and the data register (D) during operation. If the ERROR LED is on (but not blinking), it means that the setting of the user's program has exceeded the preset time-out limit. At this case, please turn the PLC RUN/STOP switch to STOP, and find out the address of the time-out program by special data register D1008. "WDT" instruction can be used to solve the problem.

**PLC Input/Output Response Time**

The total response time from the input signal to the output operation is calculated as follows:

Reaction Time = input delay time + program scan time + output delay time

Input delay time	Factory setting: 10ms. Please refer to the usage of special registers D1020~D1021.
Program scan time	Please refer to special register D1010 for detail.
Output delay time	Transistor module: 20~30us.

**Basic Instructions and Application Instructions of the PLC:**

- The basic instructions and the application instructions of the MPU of this series are totally applicable to the DELTA DVP-PLC SA/SX/SC Series MPU. Refer to the DELTA PLC Application Manual for relevant basic instructions and application instructions.
- All Delta DVP-PLC series can use DVPHPP handheld programming panel and the WPLSoft (Windows version) to edit program.

**9 TROUBLESHOOTING**

Judge the errors by the indicators on the front panel. When errors occurred on DVP PLC, please check:

**"POWER" LED**

There is a "POWER" LED at the front of the MPU. When the MPU powered on, the green LED light will be on. If the indicator is not on after the input power to MPU is normal, it indicates that the PLC is out of order. Please have this machine replaced or repaired at a dealer near you.

**PLC "RUN" LED**

Identify the status of the PLC. When the PLC is in operation, this light will be on, and users could thus use HPP or the editing program of the ladder diagram to send instructions to PLC for "RUN" or "STOP".

**"ERROR" LED**

If incorrect programs are input to the MPU, or the instructions and the components exceed the setting range, the indicator will blink. In this case, the user should check both the error codes saved in the MPU data register D1004 and the Error Code to correct the programs. The address that the error occurs will be stored in data register D1137 (the address saved in D1137 is invalid in case of common loop error).

When the ERROR LED is on (not blinking), users should make a judgment from the special relay M1008 of the MPU. If it is On, it indicates that the execution time of the program loop has exceeded the time-out setting (set by D1000). Please turn the PLC RUN/STOP switch to STOP, and find out the address of the time-out program by special data register D1008. "WDT" instruction can be used to solve the problem. Once program modification is completed, user can re-download the program of PLC and the ERROR LED will be off. If the ERROR LED is still keep on, please turn off the power and check if there's any noise or any conductive invader inside the PLC.

**"BAT.LOW" LED**

When the battery voltage is low, the "BAT.LOW" LED will be on, and the battery should be replaced as soon as possible; otherwise the user program and the data in latched area will be lost. (On the unplugged PLC, please change the battery within 3 minutes to retain the PLC internal user programs and data). Choose lithium battery TDRTL-2150/S. Please refer to the following table for battery life information.

Battery life :

Temperature((°C)	0	25	50	70
Life(Years)	9	8	6	5

Precision of calendar timer :

- At 0°C/32°F, less than -117 seconds error per month.
- At 25°C/77°F, less than 52 seconds error per month.
- At 55°C/131°F, less than -132 seconds error per month.

**"Input" LED**

The On/Off signals of the input point could be displayed through the "Input" LED, or the status of the input point could be monitored through the device monitoring function of HPP. When input signal is activated, this LED will light. Therefore, if there is any malfunction, please check it with HPP, indicators and input signals. Especially when using electrical switch with significant leakage current, it often causes unexpected result.

**"Output" LED**

Output LED indicates the output signals are on or off. Please check the following items when the LED On/Off indication does not correspond to the instructions: 1. Output contacts may be melted and stuck together due to a short circuit or overload current. 2. Check wiring and verify that the screws are tight.

**"RS-232, RS-485" LED**

"RS-232" LED will light when RS-232 is receiving data and "RS-485" LED will light when RS-485 is transferring data.