

# Altivar 312

Variable speed drives for asynchronous motors

## Modbus communication manual

04/2009





# Contents

---

Important Information	4
Before you begin	5
Documentation structure	6
Presentation	7
Connection to RS485 bus	8
Configuration of the Modbus serial port	9
Modbus protocol	11
Appendix: Non-standard RS485 schematics	16

# Important Information

---

## NOTICE

Read these instructions carefully, and look at the equipment to become familiar with the device before trying to install, operate, or maintain it. The following special messages may appear throughout this documentation or on the equipment to warn of potential hazards or to call attention to information that clarifies or simplifies a procedure.



The addition of this symbol to a Danger or Warning safety label indicates that an electrical hazard exists, which will result in personal injury if the instructions are not followed.



This is the safety alert symbol. It is used to alert you to potential personal injury hazards. Obey all safety messages that follow this symbol to avoid possible injury or death.

## **DANGER**

**DANGER** indicates an imminently hazardous situation, which, if not avoided, **will result** in death or serious injury.

## **WARNING**

**WARNING** indicates a potentially hazardous situation, which, if not avoided, **can result** in death, serious injury or equipment damage.

## **CAUTION**

**CAUTION** indicates a potentially hazardous situation, which, if not avoided, **can result** in injury or equipment damage.

## **CAUTION**

**CAUTION**, used without the safety alert symbol, indicates a potentially hazardous situation which, if not avoided, **can result** in equipment damage.

### PLEASE NOTE

The word "drive" as used in this manual refers to the controller portion of the adjustable speed drive as defined by NEC.

Electrical equipment should be installed, operated, serviced, and maintained only by qualified personnel. No responsibility is assumed by Schneider Electric for any consequences arising out of the use of this product.

© 2009 Schneider Electric. All Rights Reserved.

# Before you begin

Read and understand these instructions before performing any procedure with this drive.

## DANGER

### HAZARD OF ELECTRIC SHOCK, EXPLOSION, OR ARC FLASH

- Read and understand this manual before installing or operating the Altivar 312 drive. Installation, adjustment, repair, and maintenance must be performed by qualified personnel.
- The user is responsible for compliance with all international and national electrical code requirements with respect to grounding of all equipment.
- Many parts of this drive, including the printed circuit boards, operate at the line voltage. DO NOT TOUCH. Use only electrically insulated tools.
- DO NOT touch unshielded components or terminal strip screw connections with voltage present.
- DO NOT short across terminals PA/+ and PC/- or across the DC bus capacitors.
- Before servicing the drive:
  - Disconnect all power, including external control power that may be present.
  - Place a "DO NOT TURN ON" label on all power disconnects.
  - Lock all power disconnects in the open position.
  - WAIT 15 MINUTES to allow the DC bus capacitors to discharge. Then follow the "Bus Voltage Measurement Procedure", see Installation manual, to verify that the DC voltage is less than 42 V. The drive LEDs are not indicators of the absence of DC bus voltage.
- Install and close all covers before applying power or starting and stopping the drive.

Failure to follow these instructions will result in death or serious injury.

## DANGER

### UNINTENDED EQUIPMENT OPERATION

- Read and understand this manual before installing or operating the Altivar 312 drive.
- Any changes made to the parameter settings must be performed by qualified personnel.

Failure to follow these instructions will result in death or serious injury.

## WARNING

### DAMAGED DRIVE EQUIPMENT

Do not operate or install any drive or drive accessory that appears damaged.

Failure to follow these instructions can result in death, serious injury, or equipment damage.

## WARNING

### LOSS OF CONTROL

- The designer of any control scheme must
  - consider the potential failure modes of control paths and, for certain critical control functions,
  - provide a means to achieve a safe state during and after a path failure.

Examples of critical control functions are emergency stop and overtravel stop.

- Separate or redundant control paths must be provided for critical control functions.
- System control paths may include communication links. Consideration must be given to the implications of unanticipated transmission delays or failures of the link.<sup>a</sup>

Failure to follow these instructions can result in death, serious injury, or equipment damage.

a. For additional information, refer to NEMA ICS 1.1 (latest edition), "Safety Guidelines for the Application, Installation, and Maintenance of Solid State Control" and to NEMA ICS 7.1 (latest edition), "Safety Standards for Construction and Guide for Selection, Installation and Operation of Adjustable-Speed Drive Systems."

# Documentation structure

---

The following Altivar 312 technical documents are available on the Schneider Electric website ([www.schneider-electric.com](http://www.schneider-electric.com)) as well as on DVD-ROM (reference VW3A8200).

## Installation manual

This manual describes how to install and wire the drive.

## Programming manual

This manual describes the functions, parameters and use of the drive terminal (integrated display terminal, optional graphic display terminal and optional remote terminal).

The communication functions are not described in this manual, but in the manual for the bus or network used.

## Simplified manual

This manual is a simplified version of the User manual. This manual is delivered with the drive.

## Quick Start sheet

The Quick Start describes how to wire and configure the drive to start motor quickly and simply for simple applications. This document is delivered with the drive.

## Communication manuals: Modbus, CANopen, ...

These manuals describe the assembly, connection to the bus or network, signaling, diagnostics, and configuration of the communication-specific parameters.

They also describe the communication protocol services.

## Communication variables manual

The Communication variables manual defines the drive control processes and the drive variables which can be accessed by the communication buses: Modbus, CANopen, ...

# Presentation

---

The Modbus socket on the Altivar 312 can be used for the following functions:

- Configuration
- Settings
- Control
- Monitoring

The ATV312 drive supports:

- The 2-wire RS485 physical layer
- The RTU transmission mode

This guide contains information on installation and describes the Modbus services available. The "communication variables" guide describes the operating modes, as well as the Altivar 312 variables and parameters which can be accessed via the communication bus.

# Connection to RS485 bus

## Connection to ATV312

Connection accessories should be ordered separately (please consult our catalogues).

Connect the RJ45 cable connector to the ATV312 connector.

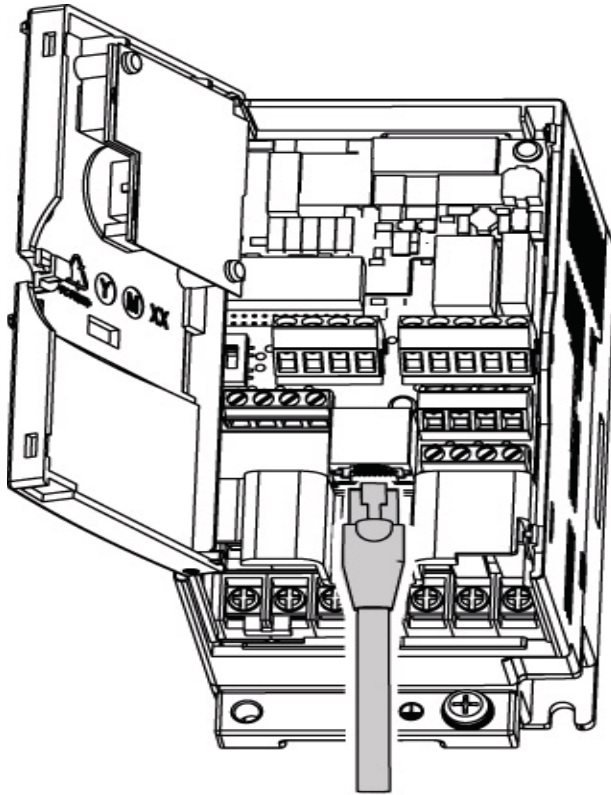

### Pin out of the ATV312 RJ45 Connector

View from underneath

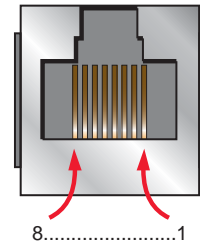

Pin	Signal
1	CANopen signal reserved
2	CANopen signal reserved
3	CANopen signal reserved
4	D1 Modbus signal
5	D0 Modbus signal
6	Not connected
7	VP (1)
8	Common Modbus signal

(1) Supply for RS232 / RS485 converter or a remote terminal

## Protection against interference

- Use the Telemecanique cable with 2 pairs of shielded twisted conductors (reference: TSXCSA100, TSXCSA200, TSXCSA500).
- Keep the Modbus cable from the power cables (30 cm minimum).
- Make any crossovers of the Modbus cable and the power cables at right-angles, if necessary.
- Connect the cable shielding to the ground of each device.

For more information, please refer to the TSX DG KBL E guide: "Electromagnetic compatibility of industrial networks and fieldbuses".

## RS485 bus schematic

The RS485 standard allows variants of different characteristics:

- polarisation
- line terminator
- distribution of a reference potential
- number of slaves
- length of bus

The new Modbus specification published on the Modbus.org site in 2002 contains precise details of all these characteristics. They are also summarised in the next paragraph (Standard schematic). The new Telemecanique devices conform to this specification.

Some devices comply with earlier specifications. The two most common networks are described in the appendices:

- "Uni-Telway schematic" page 16
- "Jbus schematic" page 17

Requirements enabling different types of protocol to coexist are given in the appendix:

- "Mixed schematic" page 18

In case of coexistence of different types of protocol, see the appendix page 21.



# Configuration of the Modbus serial port

## Communication Menu Structure

The communication parameters are part of the COM- and FLt- menus. These parameters are accessible as follows:

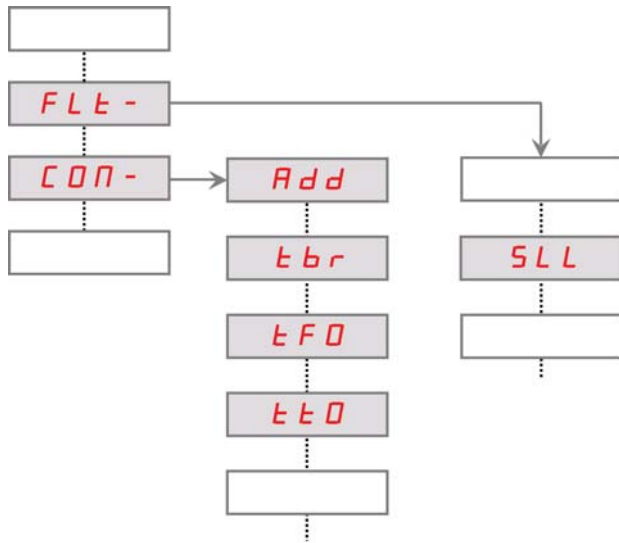

## Communication configuration - Parameters description

Parameter description	Range or listed values	default	Long name	Short name	@
Modbus Address <i>Add</i>	1 to 247	1	[Modbus Address]	<i>Add</i>	-
Modbus baud rate <i>tbr</i> <b>Important:</b> only 19.2 kbps baud rate allows to communicate with the remote display)	4.8 kbps 9.6 kbps 19.2 kbps	19.2 kbps	[Modbus baud rate]	<i>4.8</i> <i>9.6</i> <i>19.2</i>	-
Modbus format <i>tFO</i>	8O1: 8 bits, odd parity, 1 stop bit. 8E1: 8 bits, even parity, 1 stop bit. 8N1, 8 bits, no parity, 1 stop bit 8N2: 8 bits, no parity, 2 stop bits.	8E1	[8 odd 1 stop] [8 even 1 stop] [8 no 1 stop] [8 no 2 stop]	<i>8O1</i> <i>8E1</i> <i>8N1</i> <i>8N2</i>	-
Modbus time out <i>tEO</i>	Adjustable from 0.1 to 30s	10 s	[Modbus time out]	<i>tEO</i>	-
Modbus fault mgt <i>SLL</i> (This parameter is not a communication management parameter)	No action. Freewheel stop Ramp stop Fast stop"	-	[No] [Freewheel ] [Ramp Stop] [Fast Stop]	<i>nO</i> <i>YEE</i> <i>rPP</i> <i>FSE</i>	-

### WARNING

#### LOSS OF CONTROL

If Modbus fault management *SLL* is set to nO, communication control will be inhibited. For safety reasons, inhibition of communication fault should only be used for adjustment or special applications purpose.

**Failure to follow these instructions can result in death, serious injury, or equipment damage.**

# Connection to RS485 bus

## Standard schematic

The standard schematic corresponds to the Modbus specification published on the [Modbus.org](http://Modbus.org) site in 2002 (Modbus\_over\_serial\_line\_V1.pdf, Nov 2002) and in particular to the schematic of the 2-wire multidrop serial bus.

The ATV312 drive conforms to this specification.

Schematic diagram:

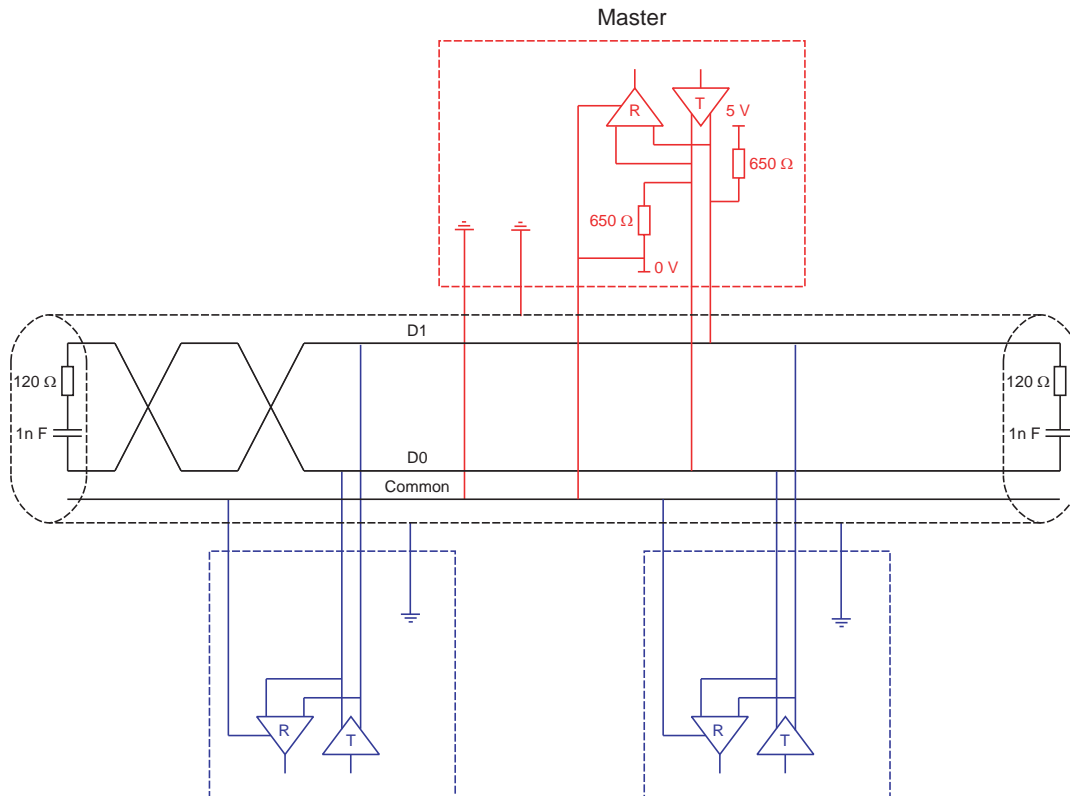

Type of trunk cable	Shielded cable with 1 twisted pair and at least a third conductor
Maximum length of bus	1000 m at 19200 bps with the Telemecanique TSX CSA●●● cable
Maximum number of stations (without repeater)	32 stations, ie. 31 slaves
Maximum length of tap links	20 m for one tap link 40 m divided by the number of tap links on a multiple junction box
Bus polarisation	One 450 to 650 Ω pull-down resistor at 5 V (650 Ω recommended) One 450 to 650 Ω pull-down resistor at the Common (650 Ω recommended) This polarisation is recommended for the master.
Line terminator	One 120 Ω 0.25 W resistor in series with a 1 nF 10 V capacitor
Common polarity	Yes (Common), connected to the protective ground at one or more points on the bus

# Modbus protocol

## Configuration of the serial link

Configuration of the serial link parameters can be accessed from the Communication menu COM-

Parameters	Possible values	Terminal display	Default value
Address <i>Ad d</i>	1 to 247	<i>001 to 247</i>	1
Speed <i>t b r</i>	4800 bps 9600 bps 19200 bps (1)	<i>4.8</i> <i>9.6</i> <i>19.2</i>	19200 bps
Format <i>t F D</i>	8 data bits, odd parity, 1 stop bit 8 data bits, even parity, 1 stop bit (1) 8 data bits, no parity, 1 stop bit 8 data bits, no parity, 2 stop bits	<i>801</i> <i>8E1</i> <i>8n1</i> <i>8n2</i>	8E1

(1) The display terminal will only work with these values.

## RTU mode

The transmission mode used is RTU mode. The frame contains no message header byte, nor end of message bytes. It is defined as follows:



The data is transmitted in binary code.

CRC16: cyclical redundancy check.

The end of the frame is detected on a silence greater than or equal to 3 characters.

## Principle

The Modbus protocol is a master-slave protocol.

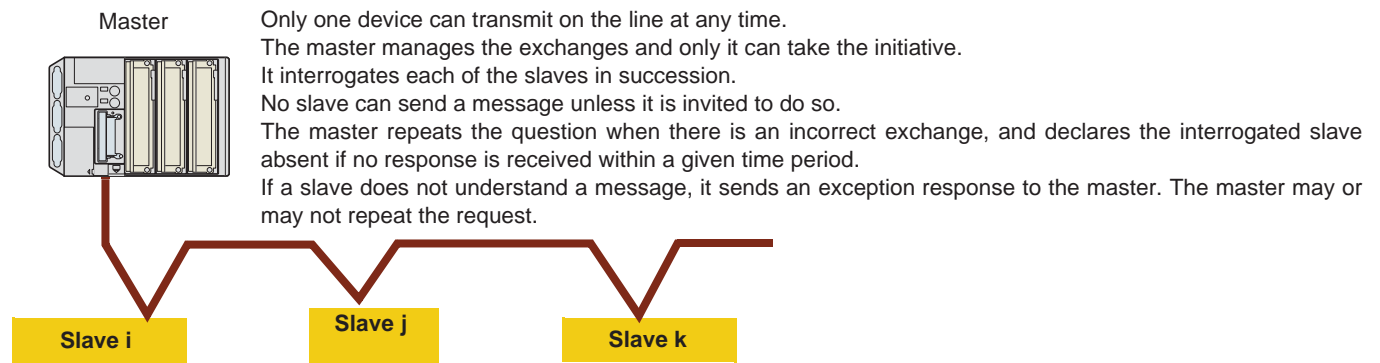

Direct slave-to-slave communications are not possible.

For slave-to-slave communication, the application software must therefore be designed to interrogate a slave and send back data received to the other slave.

Two types of dialogue are possible between master and slaves:

- the master sends a request to a slave and waits for its response
- the master sends a request to all slaves without waiting for a response (broadcasting principle)

## Addresses

- The drive Modbus address can be configured from 1 to 247.
- Address 0 coded in a request sent by the master is reserved for broadcasting. ATV 312 drives take account of the request, but do not respond to it.

# Modbus protocol

## Modbus functions

The following table indicates which Modbus functions are managed by the Altivar 312, and specifies their limits. The “read” and “write” functions are defined from the point of view of the master.

Code (decimal)	Function name	Broadcasting	Max. value of N	Modbus standard name
3	Read N output words	NO	29 words max.	Read Holding Registers
6	Write one output word	YES	–	Preset Single Register
16	Write N output words	YES	27 words max.	Preset Multiple Regs
43	Identification	NO	–	Read Device Identification

## Read N output words: function 3

**Note:** Hi = high order byte, Lo = low order byte.

This function can be used to read all ATV 312 words, both input words and output words.

Request

Slave no.	03	No. of first word		Number of words		CRC16	
		Hi	Lo	Hi	Lo	Lo	Hi
1 byte	1 byte	2 bytes		2 bytes		2 bytes	

Response

Slave no.	03	Number of bytes read	First word value		-----	Last word value		CRC16	
			Hi	Lo		Hi	Lo	Lo	Hi
1 byte	1 byte	1 byte	2 bytes			2 bytes		2 bytes	

Example: read 4 words W3102 to W3105 (16#0C1E to 16#0C21) in slave 2, using function 3, where:

- SFr = Switching frequency = 4 kHz (W3102 = 16#0028)
- tFr = Maximum output frequency = 60 Hz (W3103 = 16#0258)
- HSP = High speed = 50 Hz (W3104 = 16#01F4)
- LSP = Low speed = 0 Hz (W3105 = 16#0000)

Request	02	03	0C1E	0004	276C
---------	----	----	------	------	------

Response	02	03	08	0028	0258	01F4	0000	52B0
	Value of:			W3102	W3103	W3104	W3105	
	Parameters:			SFr	tFr	HSP	LSP	

## Write one output word: function 6

Request and response (the frame format is identical)

Slave no.	06	Word number		Value of word		CRC16	
		Hi	Lo	Hi	Lo	Lo	Hi
1 byte	1 byte	2 bytes		2 bytes		2 bytes	

Example: write value 16#000D in word W9001 (16#2329) in slave 2 (ACC = 13 s).

Request and response	02	06	2329	000D	9270
----------------------	----	----	------	------	------

# Modbus protocol

## Identification: Function 43 (16#2B)

Request

Slave no.	2B	Type of MEI 0E	ReadDeviceId 01	Object Id 00	CRC16 Lo   Hi	
1 byte	1 byte	1 byte	1 byte	1 byte	2 bytes	

Response

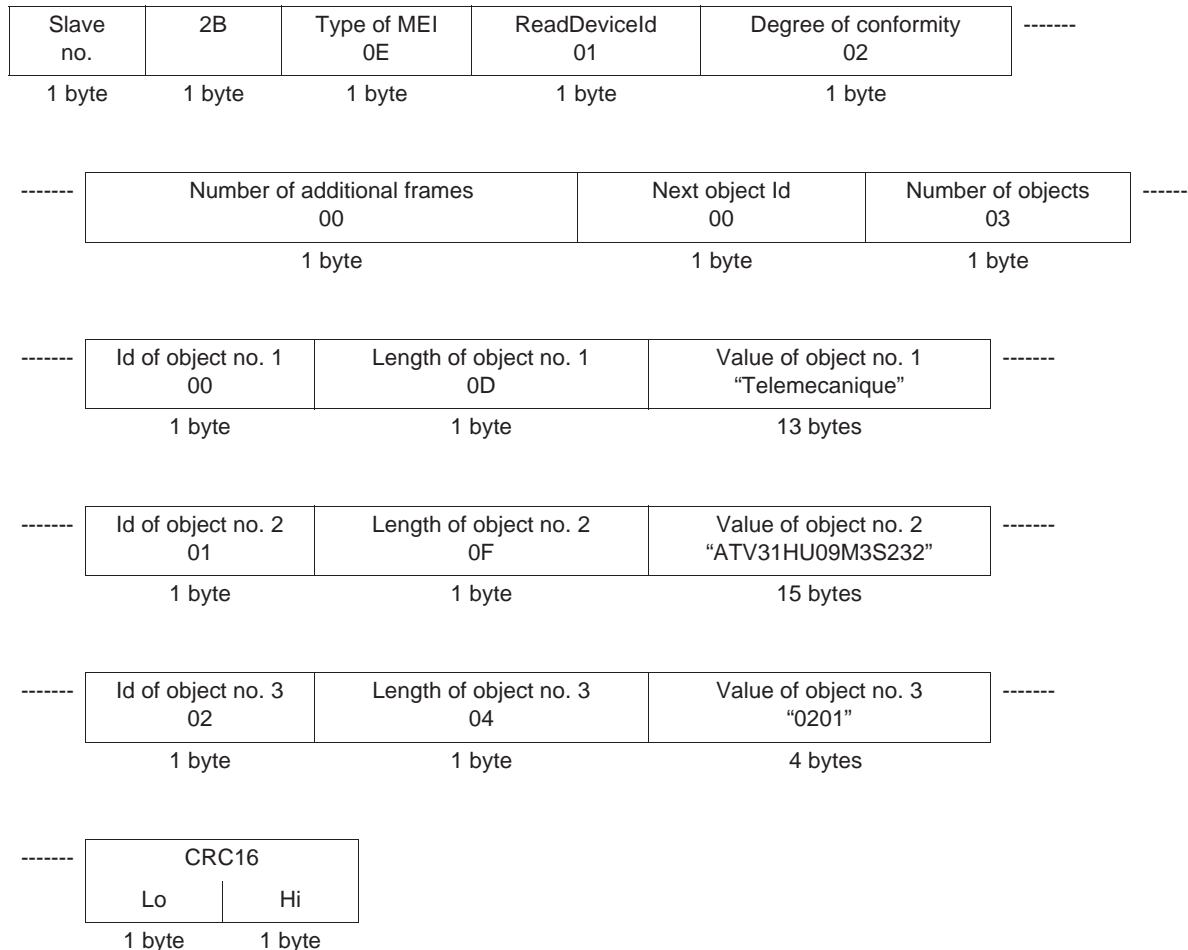

The total response size equals 48 bytes

The three objects contained in the response correspond to the following objects:

- Object no . 1: Manufacturer name (always "Telemecanique", ie. 13 bytes).
- Object no . 2: Device reference (ASCII string; *for example*: "ATV31HU09M3S232", ie. 15 bytes).
- Object no . 3: Device version, in "MMmm" format where "MM" represents the determinant and "mm" the subdeterminant (4-byte ASCII string; *for example*: "0201" for version 2.1).

**Note:** The response to function 43 may be negative; in this case, the response located at the top of the next page is sent by the Altivar 312 rather than the response described above.

# Modbus protocol

## Negative response

Slave no.	2B + 80 AB	Type of MEI 0E	Error code 00 to 02	CRC16	
				Lo	Hi
1 byte	1 byte	1 byte	1 byte	1 byte	1 byte

- Error code:
- 16#0 No error  
0 =
  - 16#0 The "Request code" (16#2B), the "Type of MEI" (16#0E) or the "ReadDeviceId" (16#01) contained in the request is incorrect  
1 =
  - 16#0 The "Object Id" (16#00) contained in the request is incorrect  
2 =

Example: Following the request from the Modbus master, slave 2 identifies itself as follows:

- Manufacturer name = "Telemecanique" (13 bytes)
- Device name = "ATV31HU09M3S232" (15 bytes)
- Device version = "0201" (4 bytes)

Request

02	2B	0E	01	00	3477
----	----	----	----	----	------

Response

02	2B	0E	01	02	00	00	03	-----

-----

00	0D	54 45 4C 45 4D 45 43 41 4E 49 51 55 45	-----
----	----	--	-------

-----

01	0F	41 54 56 33 31 48 55 30 39 4D 33 53 32 33 32	-----
----	----	--	-------

-----

02	04	30 32 30 31	A80F
----	----	-------------	------

## Write N output words: function 16 (16#10)

### Request

No. slave	10	No. of first word		Number of words	Number of bytes	Value of first word		CRC16
		Hi	Lo			Hi	Lo	
1 byte	1 byte	2 bytes		2 bytes	1 byte	2 bytes		2 bytes

### Response

Slave no.	10	No. of first word		Number of words		CRC16	
		Hi	Lo	Hi	Lo	Lo	Hi
1 byte	1 byte	2 bytes		2 bytes		2 bytes	

Example: write values 20 and 30 in words W9001 and W9002 in slave 2

(ACC = 20 s and DEC = 30 s)

Request

02	10	2329	0002	04	0014	001E	517F
----	----	------	------	----	------	------	------

Response

02	10	2329	0002	8FED
----	----	------	------	------

# Modbus protocol

---

## Exception responses

An exception response is returned by a slave when it is unable to perform the request which is addressed to it.

Format of an exception response:

Slave no.	Response code	Error code	CRC16	
			Lo	Hi
1 byte	1 byte	1 byte	2 bytes	

**Response code:** request function code + 16#80.

**Error code:**

- 1 = The function requested is not recognized by the slave
- 2 = The bit or word addresses indicated in the request do not exist in the slave
- 3 = The bit or word values indicated in the request are not permissible in the slave
- 4 = The slave has started to execute the request but cannot continue to process it completely

## CRC16 calculation

The CRC16 is calculated on all the message bytes by applying the following method:

Initialize the CRC (16-bit register) to 16#FFFF.

Enter the first to the last byte of the message:

CRC XOR <byte> → CRC

Enter 8 times

Move the CRC one bit to the right

If the output bit = 1, enter CRC XOR 16#A001 → CRC

End enter

End enter

The CRC obtained will be transmitted with the low order bytes sent first, followed by the high order ones (unlike the other data contained in Modbus frames).

XOR = exclusive OR.

# Appendix: Non-standard RS485 schematics

## Uni-Telway schematic

The Uni-Telway bus schematic has been used by Telemecanique for its drives and soft starters (ATV58, ATV28, etc).

Schematic diagram:

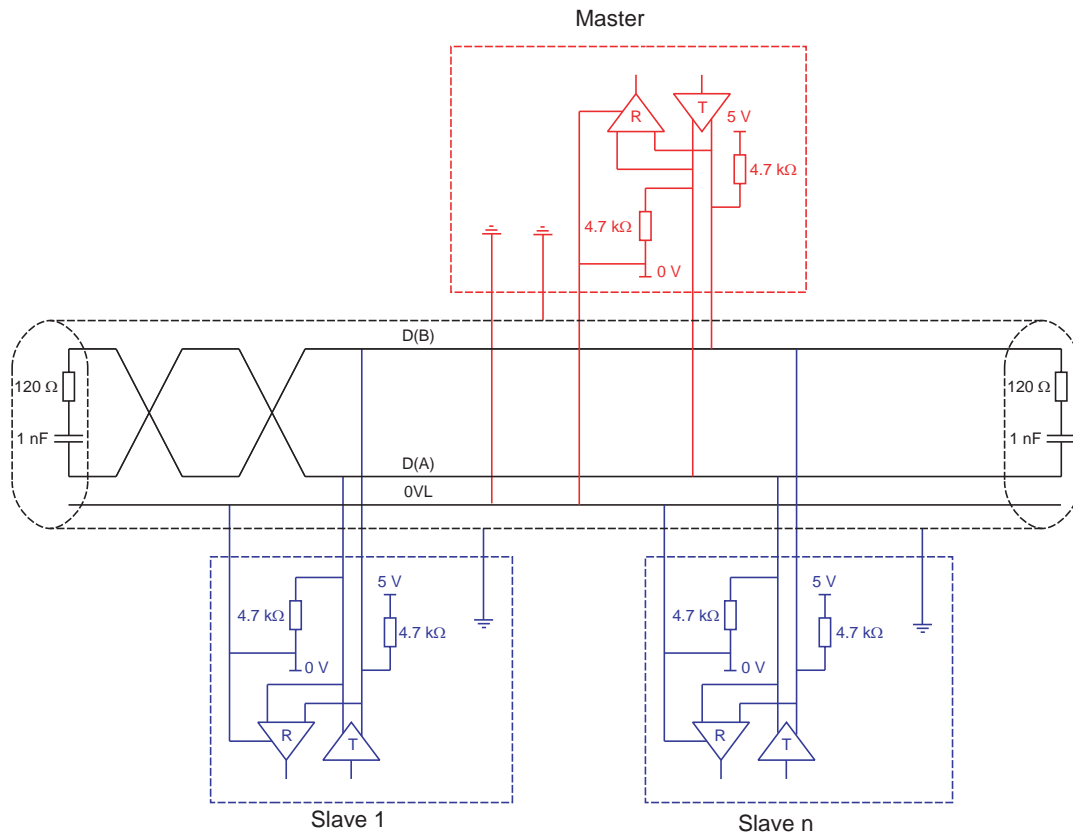

Type of trunk cable	Cable with 2 twisted pairs shielded in pairs
Maximum length of bus	1000 m at 19200 bps
Maximum number of stations (without repeater)	29 stations, ie. 28 slaves
Maximum length of tap links	<ul style="list-style-type: none"> <li>• 20 m</li> <li>• 40 m divided by the number of tap links on a multiple junction box</li> </ul>
Bus polarisation	For the master and each slave: <ul style="list-style-type: none"> <li>• One 4.7 kΩ pull-down resistor at 5 V</li> <li>• One 4.7 kΩ pull-down resistor at 0 VL</li> </ul>
Line terminator	One 120 Ω 0.25 W resistor in series with a 1 nF 10 V capacitor
Common polarity	Yes (0 VL) and high impedance placed between 0 VL and the ground in each station



# Appendix: Non-standard RS485 schematics

## Jbus schematic

Schematic diagram:

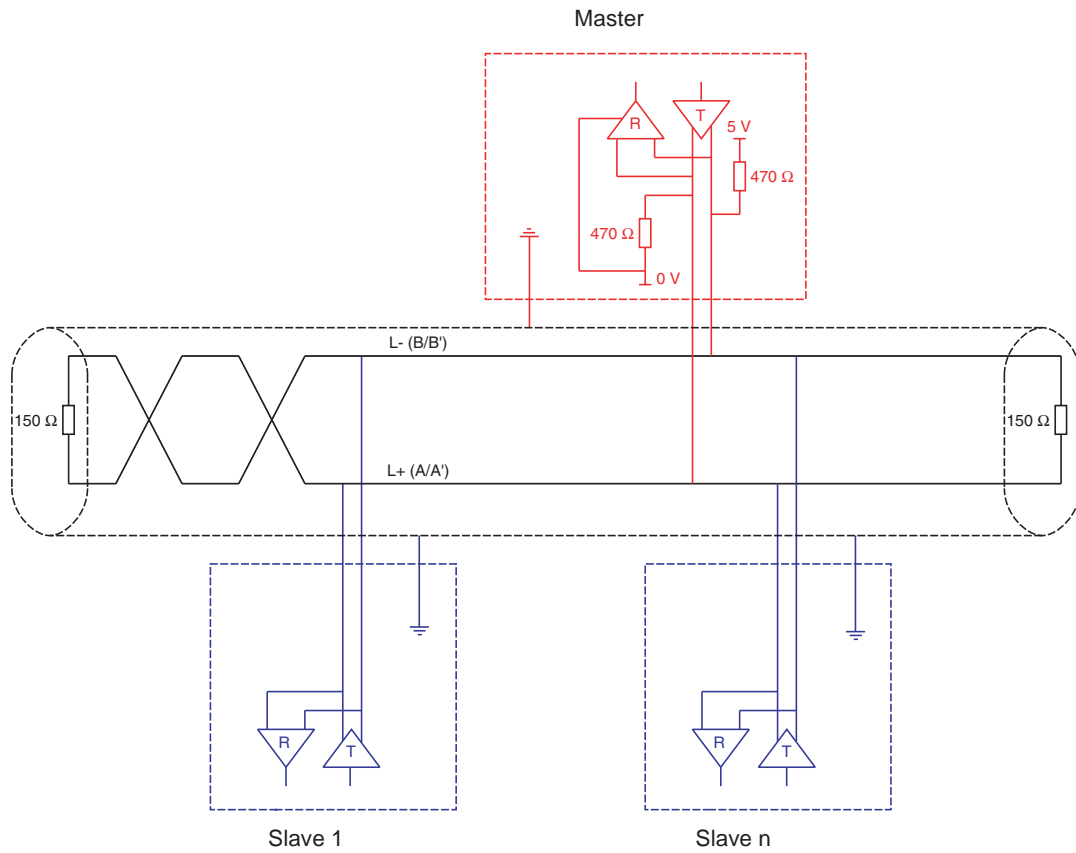

Type of trunk cable	Cable with 1 shielded twisted pair
Maximum length of bus	1300 m at 19200 bps
Maximum number of stations (without repeater)	32 stations, ie. 31 slaves
Maximum length of tap links	3 m
Bus polarisation	One 470 Ω pulldown resistor at 5 V One 470 Ω pulldown resistor at 0 V This polarisation is often provided in the master.
Line terminator	One 150 Ω resistor
Common polarity	No

# Appendix: Non-standard RS485 schematics

## Mixed schematic

Slaves with 4.7 kΩ polarisation can be integrated into a standard schematic. Suitable polarisation (Rp) must be calculated.

Schematic diagram:

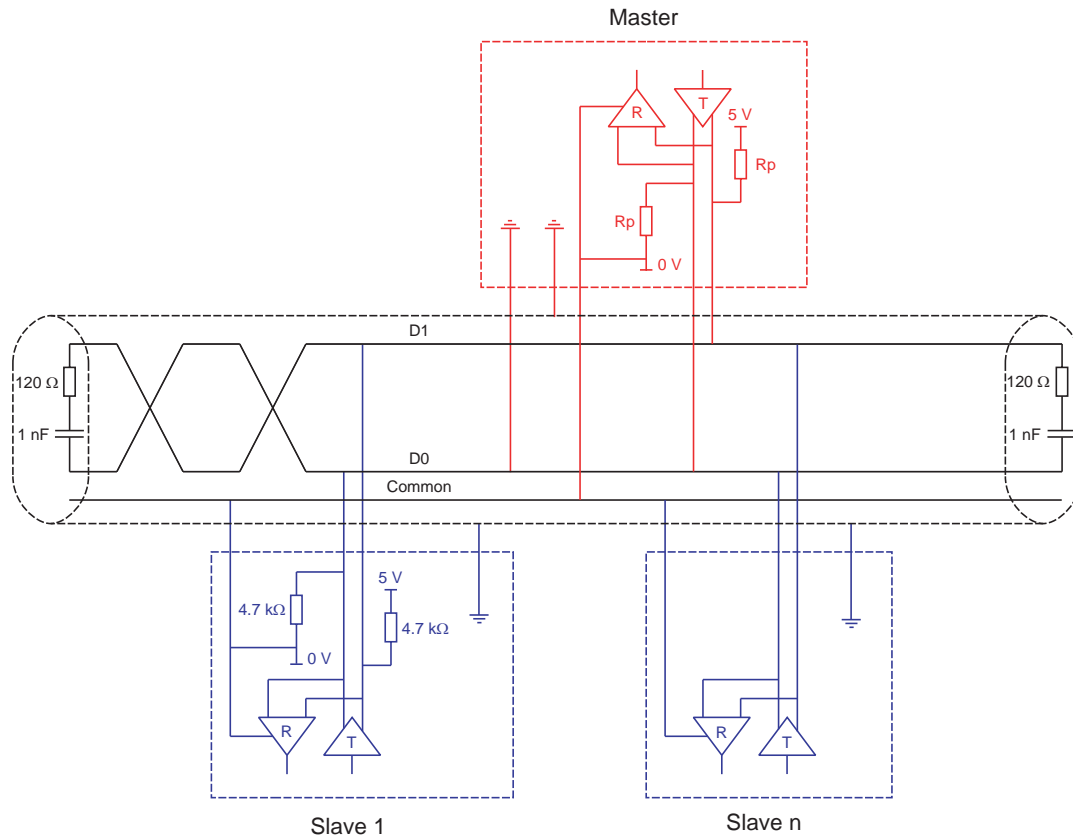

Type of trunk cable	Shielded cable with 1 twisted pair and at least a 3 <sup>rd</sup> conductor
Maximum length of bus	1000 m at 19200 bps
Maximum number of stations (without repeater)	At most 32 stations ie. 31 slaves (depending on Rp and the number of 4.7 kΩ resistors)
Maximum length of tap links	<ul style="list-style-type: none"> <li>• 20 m for a single tap link</li> <li>• 40 m divided by the number of tap links on a multiple junction box</li> </ul>
Bus polarisation	<ul style="list-style-type: none"> <li>• One pull-down resistor at 5 V (Rp)</li> <li>• One pull-down resistor at the Common (Rp)</li> </ul> This polarisation can be provided in the master. The value of Rp should be validated (or determined) by calculating the equivalent polarisation (Re) according to the polarisation of the master and slave stations. The value of Re must be between 162 Ω and 650 Ω (recommended value: 650 Ω).
Line terminator	One 120 Ω 0.25 W resistor in series with a 1 nF 10 V capacitor
Common polarity	Yes (Common)

- To calculate the polarisation (Rp), all station polarisations must be deemed to be connected in parallel.

### Example:

If the bus Rp polarisation is 470 Ω (installed in the master) and 2 slaves have 4700 Ω polarisation, the equivalent polarisation is:

$$1/Re = 1/470 + 1/4700 + 1/4700$$

$$\text{ie. } Re = 1 / (1/470 + 1/4700 + 1/4700)$$

and therefore Re = 390 Ω.

390 Ω is greater than 162 Ω, and the schematic is correct.

For an ideal equivalent polarisation (650 Ω), Rp bus polarisation can be installed so that:

$$1/650 = 1/Rp + 1/4700 + 1/4700$$

$$\text{ie. } Rp = 1 / (1/650 - 1/4700 - 1/4700)$$

and therefore Rp = 587 Ω.

- If the master is fitted with a 470 Ω polarisation, it is possible to connect a maximum of 18 slaves with 4.7 kΩ polarisation.

# Appendix: Non-standard RS485 schematics

---

## Recommendations for setting up a Modbus network using non-standard devices

1. Identify polarities D0 and D1.

They are labeled in a variety of ways according to the specification used:

Modbus	D0	D1	Common
EIA/TIA-485	A / A'	B / B'	C / C'
UNI-TELWAY	D(A)	D(B)	0VL
Jbus	RD + / TD + L +	RD - / TD - L -	

However, certain RS485 electronic components are labeled in the opposite way to the EIA/TIA-485 standard.

It may be necessary to perform a test by connecting a master to a slave, then reversing the connection in the event of failure.

2. Check polarizations.

Study the documentation supplied with the devices to determine the polarization resistance.

If there is one, check that the value is correct (see Mixed schematic page [18](#))

Polarization is not always possible. For example, in the event of the 5 V not being available in the master.

3. Select a line terminator.

In the case of polarization, select an RC line terminator ( $R = 120 \Omega$ ,  $C = 1 \text{ nF}$ ).

If polarization is not possible, select an R line terminator ( $R = 150 \Omega$ ).

BBV52816

ATV312\_Modbus\_EN\_V1.pdf

04/2009

[efesotomasyon.com](http://efesotomasyon.com)