

Variable speed drives
for asynchronous motors

Altivar 38

Mastering *elements*
for *more comfort*

Catalogue
December

2002



Telemecanique

Schneider
Electric
Building a New Electric World

efesotomasyon.com

Variable speed drives for asynchronous motors

Altivar 38

Presentation	pages 2 and 3
Characteristics	pages 4 to 7
References	page 8
Options	
b Dialogue	page 9
b Accessories	page 10
b Line chokes	page 11
b Radio interference input filters	pages 12 and 13
b Output filters and motor chokes	pages 14 and 15
b I/O extension, customer-specific cards	pages 16 and 17
b Communication	pages 18 and 19
Power Suite advanced dialogue solutions	pages 20 and 21
Dimensions	pages 22 to 24
Mounting	page 25
Schemes	pages 26 to 28
Electromagnetic compatibility	page 29
Combinations (motors-starters)	pages 30 and 31
Functions	pages 32 to 43

Variable speed drives for asynchronous motors Altivar 38

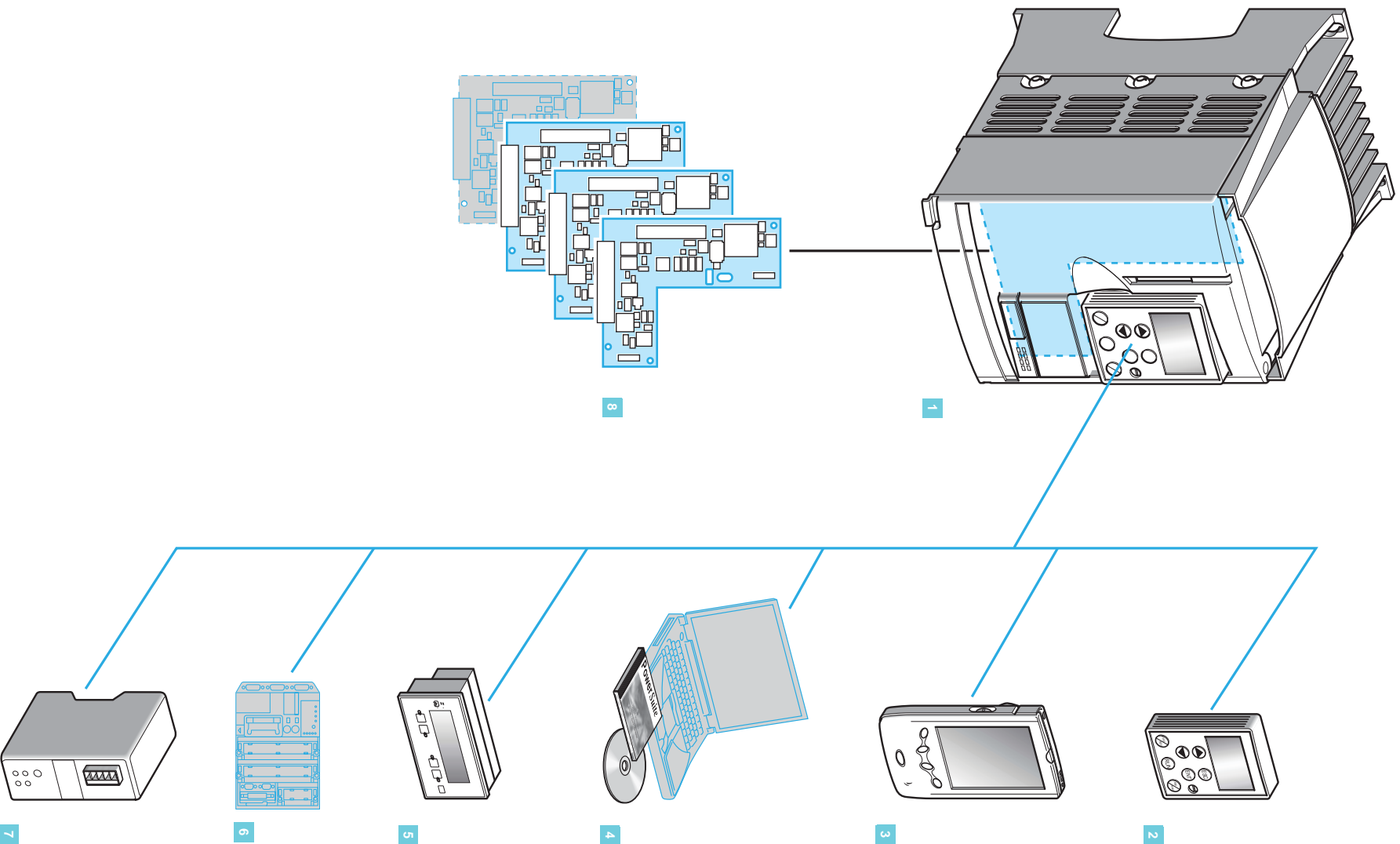

Variable speed drives for asynchronous motors Altivar 38

Applications

The Altivar 38 is a frequency inverter for three-phase asynchronous motors powered by a three-phase supply 380 V -10% to 460 V +10% or 480 V +5% in the power range 0.75 kW to 315 kW.

The Altivar 38 has been designed for state-of-the-art applications in heating, ventilation and air conditioning (HVAC) in industrial and commercial buildings:

- b ventilation
- b air conditioning
- b pumping

The Altivar 38 can reduce operating costs in buildings by optimizing energy consumption whilst improving user comfort. Its numerous integrated options enable it to be adapted to and incorporated into electrical installations and sophisticated control systems.

The need for **electromagnetic compatibility** was taken into account at the outset of designing the drive. Depending on the drive rating, filters and chokes are either built-in or available as optional accessories.

Functions

The Altivar 38 (**1**) is supplied ready for use in pumping and ventilation applications. It comprises a terminal (**2**) which can be used to modify programming, adjustment, control or monitoring functions in order to adapt and customize the application to meet individual customer requirements.

b Specific functions for pumping/ventilation:

- v Energy saving
- v Automatic catching a spinning load with speed detection (catch on the fly)
- v Adaptation of current limiting according to speed
- v Faster/slower, preset speeds
- v Integrated PI control, with preset PI references
- v Electricity and service hours meter
- v Motor noise reduction

b Protection functions:

- v Motor and fan thermal protection via PTC thermal probe
- v Protection against overloads and overcurrents in continuous operation
- v Machine mechanical protection via jump frequency function
- v Protection via multiple fault management and configurable alarms

b Easy to integrate into control systems:

- v 4 logic inputs, 2 relay outputs, 2 analogue inputs and 1 analogue output
- v Plug-in I/O connectors
- v Display of electrical variables and operating indicators
- v An RS 485 multidrop serial link with Modbus protocol as standard in the drive. This serial link can be used to connect PLCs (**6**), a PC, communication gateways or one of the available programming tools.

Options

b PowerSuite advanced dialogue solutions:

3 solutions are available, with plain text display in 5 languages (English, French, German, Spanish, Italian) and configuration memory:

- v Pocket PC for PowerSuite (**3**)
- v PowerSuite software workshop for PC (**4**)
- v Magelis display unit (**5**)

b Customizing the application:

- v I/O extension cards (**8**)
- v Application cards (**8**):
- v pump switching, multi-motor function, multiple parameter settings and cycles
- v Communication cards for bus or network (**8**):
- METASYS N2, Ethernet, Fpico, Uni-Telway/Modbus, Modbus Plus, AS-i, Profibus DP, Interbus-S, CANopen, DeviceNet
- v Communication module for LonWorks bus (**7**)

Variable speed drives for asynchronous motors Altivar 38

Environment

Conformity to standards

Altivar 38 drives have been developed to conform to the strictest national and international standards and the recommendations relating to electrical industrial control devices (IEC, EN, NFC, VDE), in particular:
 p Low voltage EN 50178
 p EMC immunity:
 - IEC 1000-4-2/EN 61000-4-2 level 3
 - IEC 1000-4-3/EN 61000-4-3 level 3
 - IEC 1000-4-4/EN 61000-4-4 level 4
 - IEC 1000-4-5/EN 61000-4-5 level 3
 - IEC 1800-3/EN 61800-3, environments 1 and 2
 p EMC, radiated and conducted emissions:
 - IEC 1800-3/EN 61800-3, environments: 2 (industrial supply) and 1 (public supply), restricted distribution
 - EN 55011 class A (drives with built-in radio interference filters)
 - EN 55022 class B, with additional filters

e marking

The drives have been designed to meet the requirements of the European low voltage (73/23/EEC and 93/68/EEC) and EMC (89/336/EEC) directives.
 Altivar 38 drives are therefore permitted to carry the e European Union mark.

Product certification	Conforming to EN 50178	ATV 38HU18N4 to HD23N4 and ATV 38HD25N4p to HD79N4p drives	IP 21 and IP 41 on upper part	DNV ¹ (up to 75 kW) UL and CSA
Degree of protection	Conforming to IEC 60068-2-6	ATV 38HC10N4X to HC33N4X drives	IP 00 on lower part (1), IP 20 on other sides	
Vibration resistance	Conforming to IEC 60068-2-6	ATV 38HU18N4 to HD23N4 and ATV 38HD25N4p to HD79N4p drives ATV 38HC10N4X to HC33N4X drives	1.5 mm peak from 2 to 13 Hz 1 gn from 13 to 200 Hz 0.6 gn from 10 to 55 Hz 1 gn from 55 to 150 Hz	
Shock resistance	Conforming to IEC 60068-2-27	All ratings	15 gn for 11 ms	
Maximum ambient pollution	Conforming to UL 508C Conforming to IEC 664-1 and EN 50718	ATV 38HD25N4 to HD79N4 and HD25N4X to HD79N4X drives ATV 38HU18N4 to HD23N4 and ATV 38HC10N4X to HC33N4X drives	Level 3 Level 2	
Maximum relative humidity around the device	Conforming to IEC 60068-2-3	All ratings	93% without condensation or dripping water	
Ambient air temperature	Storage Operation	ATV 38HU18N4 to HU90N4 drives	- 25...+ 65 - 10...+ 50 without derating Up to + 60 with current derating of 2.2% per °C above 50°C	
Maximum operating altitude		ATV 38HD25N4 to HD79N4 and HD25N4X to HD79N4X drives	- 10...+ 40 without derating Up to + 60 with ventilation kit, current derating of 2.2% per °C, above 40°C	
Operating position			1000 without derating (above this, derate the current by 1% per additional 100 m)	Vertical
Drive characteristics				
Output frequency range				
Configurable switching frequency	Without derating, in continuous operation	ATV 38HU18N4 to HD46N4 and HD25N4X to HD46N4X drives ATV 38D54N4 to HD79N4 and HD54N4X to HC33N4X drives	Hz 0.1...500 KHz 0.5-1-2-4 KHz 0.5-1-2	
	Without derating with intermittent operating cycle or with derating by one power rating in continuous operation	ATV 38HU18N4 to HD23N4 drives ATV 38HD25N4 to HD46N4 and HD25N4X to HD46N4X drives ATV 38HD54N4 to HD79N4 and HD54N4X to HD79N4X drives ATV 38HC10N4X to HC33N4X drives	Hz 8-12-16 KHz 8-12 KHz 4-8 KHz 4	
Speed range				1...10
Transient overtorque				110% of the nominal motor torque (typical value at ± 10%) for 60 s
Braking torque				30% of the nominal motor torque without braking resistor (typical value) for low power ratings
Principle of motor control				Pulse width modulation (PWM) (1) A protection device to prevent direct contact by personnel must be added.

Variable speed drives for asynchronous motors Altivar 38

Electrical characteristics			
Power supply	a.c. voltage	V	ATV 38ppppN4 et ppppN4X drives: 380 - 10% to 460 + 10% or 480 + 5%, three-phase
	Frequency	Hz	50 ± 5% or 60 ± 5%
Output voltage			Maximum voltage equal to line supply voltage
Electrical isolation			Electrical isolation between power and control (inputs, outputs, power supplies)
Available internal supplies			Protected against short-circuits and overloads: - 1 x + 10 V (0. + 10%) supply for the reference potentiometer (1... 10 k Ω), maximum current 10 mA - 1 x + 24 V supply (min. 20 V, max. 30 V) for control inputs, maximum current 200 mA
Analogue inputs AI			1 analogue voltage input AI1: 0-10 V, impedance 30 k Ω 1 analogue current input AI2: 0-20 mA, impedance 100 Ω (reassignable to X-Y mA by programming X and Y with a precision of 0.1 mA) Frequency resolution at analogue reference: 0.1 Hz for 100 Hz (10 bits), precision ± 1%, linearity ± 0.5% of the maximum output frequency Sampling time: 4 ms max. Other analogue inputs: see option cards
Analogue output AO1			Assignable analogue output 0-20 mA, max. load impedance 500 Ω (reassignable to X-Y mA by programming X and Y from 0 to 20 with a precision of 0.1 mA) Resolution 0.04 mA (9 bits), linearity ± 0.1 mA, precision ± 0.2 mA Max. sampling time 2 ms Other analogue inputs: see option cards
Logic inputs LI			4 assignable logic inputs, impedance 3.5 k Ω , compatible with PLC level 1, standard IEC 65A-68. Maximum length of shielded cable: 100 m + 24 V power supply (min. 11 V, max. 30 V), State 0 if < 5 V, state 1 if ≥ 11 V Sampling time: 2 ms max. Other logic inputs: see option cards
Logic outputs			2 relay logic outputs R1 (fault relay) and R2 (assignable) 1 C/O contact protected against overvoltages (relay R1) 1 N/O contact protected against overvoltages (relay R2) Minimum switching capacity: 10 mA for C 24 V Maximum switching capacity: - on resistive load (cos ϕ = 1): 5 A for a 250 V or C 30 V - on inductive load (cos ϕ = 0.4 and L/R = 7 ms): 1.5 A for a 250 V or C 30 V. - Other outputs: see option cards
Maximum connection capacity of I/O			1.5 mm ² (AWG 14)
Communication			RS 485 multidrop serial link with Modbus protocol integrated into the drive Transmission speed: 9600 or 19200 bps, no parity Use: - connecting a terminal (option) or - connecting a microprocessor card or - connecting a PC or a pocket PC (options) or - connecting one or more PLCs
Acceleration and deceleration ramps			Ramp profiles can be selected: linear, S or U. Possibility of 2 ramp ranges which can be switched via frequency threshold or logic input. Can be adjusted separately between 0.05 and 999.9 s (precision 0.1 s) Automatic adaptation of deceleration ramp times if the braking capacity is exceeded (configurable option)
Braking to a standstill			By d.c. injection: - by a signal on an assignable logic input - automatically on stopping as soon as the frequency drops below 0.1 Hz, for a time which can be set between 0 and 30 s or alternately set - continuous
Main protection and safety features of the drive			Short-circuit protection: - between output phases - between output phases and earth - on internal supply outputs Thermal protection against excessive overheating and overcurrents Mains undervoltage and overvoltage safety circuits Loss of supply phase safety circuit (prevents single phase operation of 3-phase drives)
Motor protection			Thermal protection integrated into the drive via continuous calculation of I ² t taking the speed into account: - The motor thermal state is saved when the drive is powered down. - The function can be modified via the terminal or by using the PowerSuite advanced dialogue solutions, depending on the type of motor (force-cooled or self-cooled). Protection against motor phase breaks Protection via PTC probes with option card
Insulation resistance to earth	M Ω		> 500 (electrical isolation) at C 500 V
Dielectric strength	V		C 2830 earth/power a 2000 control/power

Variable speed drives for asynchronous motors Altivar 38

Torque characteristics (typical curves)

The curves below define the available continuous torque and transient overtorque for both force-cooled and self-cooled motors.
The only difference is in the ability of the motor to provide a high continuous torque at less than half the nominal speed.

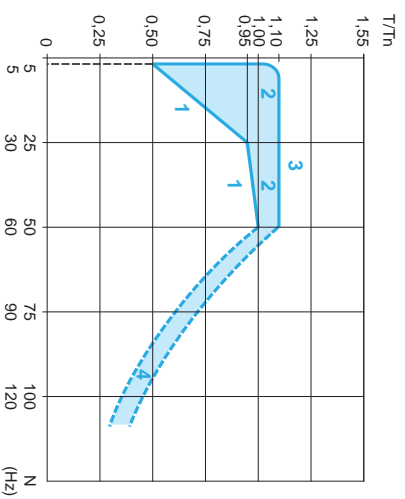

- 1 Self-cooled motor: continuous useful torque
- 2 Force-cooled motor: continuous useful torque
- 3 Transient overtorque
- 4 Torque in overspeed at constant power

Caution: Check the mechanical overspeed characteristics of the selected motor with the manufacturer.

Motor thermal protection

The Altivar 38 drive features motor thermal protection designed specifically for self-cooled or forced-cooled variable speed motors.

This motor thermal protection is designed for a maximum ambient temperature of 40°C around the motor.

If the temperature around the motor exceeds 40°C, thermal protection should be provided directly by thermistor probes integrated into the motor using one of the available option cards.

Variable speed drives for asynchronous motors

Altivar 38

Special uses

Switching the motor at the drive output

The drive can be switched when locked or unlocked. If the drive is switched on-the-fly (drive locked), the motor is controlled and accelerates until it reaches the reference speed smoothly following the acceleration ramp. The "flying restart" must be configured for this type of use and the "loss of motor phase" protection function must be disabled.

Example: breaking of downstream contactor

Typical applications: breaking safety circuit at drive outputs, "bypass" function, switching of motors connected in parallel

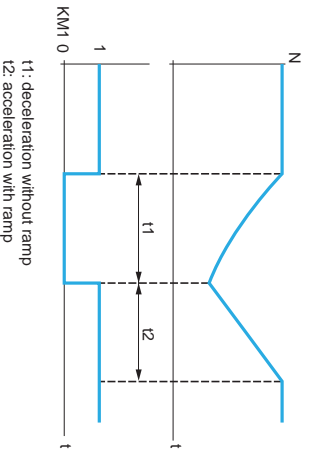

t1: deceleration without ramp
t2: acceleration with ramp

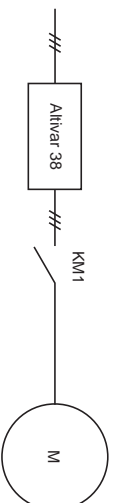

Operation with intermittent cycle and high switching frequency

If the operating conditions are intermittent and the maximum cumulative running time is 36 s per 60 s cycle (load factor 60%), it is possible to operate at a high switching frequency without derating the power.

- Switching frequencies (in KHz)
- b 8-12-16 for ATV 38HU18N4 to HD23N4 drives
 - b 8-12 for ATV 38HD25N4p to HD46N4p drives
 - b 4 for ATV 38HD54N4p to HC33N4X drives

Connecting motors in parallel

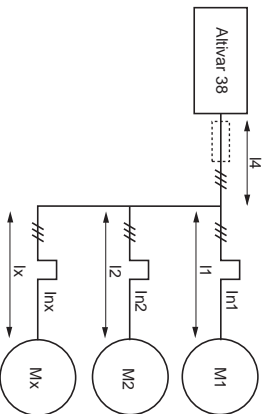

Calculating the drive rating:
In drives > In1 + In2 = ... Inx

The nominal current of the drive must be greater than or equal to the sum of the currents of the motors to be controlled. In this case, provide external thermal protection for each motor using thermal probes or relays. If the number of motors connected in parallel is ≥ 3 , it is advisable to install an output filter between the drive and the motors or to reduce the switching frequency.

If several motors are used in parallel, there are 2 possible scenarios:

- the motors have equal power ratings, in which case the torque characteristics will remain optimised after the drive has been configured
- the motors have different power ratings, in which case the drive configuration will be incompatible for the motors with the lowest power ratings and the overtorque at low speed will be considerably reduced.

Ensure that the cables are the correct length.

As the leakage currents are proportional to the total length of the cable between the drive and the motors, ensure $L_y \leq 100$ m by $L = l_1 + l_2 + l_x + l_4$.
For longer lengths, please consult your Regional Sales Office.

Variable speed drives for asynchronous motors

Altivar 38

Variable torque applications (110% T_n)

3-phase supply voltage: 380...460 V 50/60 Hz

Motor	Line supply voltage ⁽²⁾		Altivar 38		Max. transient current ⁽³⁾	Power dissipated at nominal load ⁽⁴⁾	Reference With integral EMC filters	No EMC filters	Weight
	Line current at 400 V	Line supply voltage	Nominal drive current	Max. transient current					
0.75	3.1	2.1	2.3	55	55	ATV 38HU18N4	-	3.800	
1.5	5.4	3.7	4.1	65	105	ATV 38HU29N4	-	3.800	
2.2	7.3	5.4	6	105	145	ATV 38HU41N4	-	3.800	
3	10	7.1	7.8	145	180	ATV 38HU54N4	-	6.900	
4	12.3	9.5	10.5	180	220	ATV 38HU72N4	-	6.900	
5.5	16.3	11.8	13	220	230	ATV 38HU90N4	-	6.900	
7.5	24.3	16	17.6	230	340	ATV 38HD12N4	-	13.000	
11	33.5	22	24.2	340	410	ATV 38HD16N4	-	13.000	
15	43.2	30	33	410	670	ATV 38HD23N4	-	15.000	
18.5	42	37	41	670	-	ATV 38HD25N4	-	34.000	
22	49	44	49	750	-	ATV 38HD28N4	-	34.000	
30	65	60	66	925	-	ATV 38HD33N4	-	34.000	
37	79	72	80	1040	-	ATV 38HD46N4	-	34.000	
45	95	85	94	1045	-	ATV 38HD54N4	-	34.000	
55	118	105	116	1265	-	ATV 38HD54N4X	-	57.000	
75	158	138	152	1730	-	ATV 38HD79N4	-	57.000	
90	156 (5)	173	190	2250	-	ATV 38HD79N4X	-	57.000	
110	191 (5)	211	232	2750	-	ATV 38HC10N4X	-	49.000	
132	229 (5)	253	278	3300	-	ATV 38HC13N4X	-	75.000	
160	279 (5)	300	330	4000	-	ATV 38HC15N4X	-	77.000	
200	347 (5)	370	407	5000	-	ATV 38HC19N4X	-	159.000	
220	384 (5)	407	448	5500	-	ATV 38HC25N4X	-	166.000	
250	433 (5)	450	495	6250	-	ATV 38HC28N4X	-	168.000	
280	485 (5)	503	553	7000	-	ATV 38HC31N4X	-	168.000	
315	536 (5)	564	620	7875	-	ATV 38HC33N4X	-	168.000	

(1) Value indicated on the motor rating plate. These power levels are for the maximum switching frequency permitted by the drive (2 or 4 kHz depending on the rating) in continuous operation without derating. For switching frequencies above this level, the drive must be in intermittent operation or it must be set one rating lower (see special uses on the previous pages).

(2) The prospective short-circuit current at 400 V is 5 kA for ATV 38HU18N4 to HU90N4 drive ratings and 22 kA for ATV 38HD25N4p to HC33N4X drive ratings.

(3) For 60 seconds.

(4) These power levels are given for the maximum switching frequency permitted by the drive in continuous operation (2 or 4 Hz, depending on the rating).

(5) Line chokes must be used if the prospective short-circuit line current is greater than 22 kA. The current values given include the addition of a line choke.



ATV 38HU18N4



ATV 38HD28N4



ATV 38HC19N4X

Variable speed drives for asynchronous motors

Altivar 38

Options: dialogue

Operator terminal

The removable operator terminal fits into a designated slot on the front panel of the drive. The operator terminal is supplied with the drive or can be ordered separately.

The operator terminal can be used:

- in 5 languages: (English, French, German, Spanish, Italian)
- to control, adjust and configure the drive
- for visible remote signalling
- to save and download configurations (4 files can be saved)

Its maximum operating temperature is 60°C.

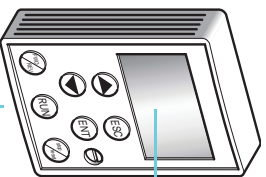

Display (backlit)



Flashing: indicates the selected direction of rotation



Steady: indicates the direction of motor rotation

LOC Indicates control via the display module

PROG

Appears in setup and programming mode

Flashing: indicates that a value has been modified but not saved

4 digits visible at 5 m: displays numeric values and codes

One line of 16 characters: displays messages in plain text

The keys are used:
To adjust and configure the drive
To control the drive

Description	Reference (if ordered separately)	Weight kg
Operator terminal	VW3 A58101	0,200

Kit for remote operator terminal

The removable operator terminal can be used remotely, mounted on an enclosure door, using this kit.

Description	Reference	Weight kg
Kit comprising: - 1 cable fitted with connectors, length 3 m - seals and screws for IP 65 mounting on an enclosure door - installation guide	VW3 A58103	0,200

I/O extension cards, customer-specific cards

See pages 16 and 17.

Communication option

See pages 18 and 19.

PowerSuite advanced dialogue solutions

See pages 20 and 21.

Connection kit for RS 485

This kit can be used to connect the drive to PLCs, operator terminals, etc., via the RS 485 multidrop serial link. The kit is connected instead of the operator terminal (the two cannot be used simultaneously).

Description	Reference	Weight kg
Connection kit for RS 485 comprising: - 1 x 3 m cable with 1 male 9-way SUB-D connector and 1 male 15-way SUB-D connector - installation guide	VW3 A58306	0,200

Variable speed drives for asynchronous motors

Altivar 38

Accessories



VW3 A58823

Control card fan kit

The fan kit enables the drive to operate at an ambient temperature of 60°C, for example if it is mounted in an IP 54 enclosure. The circulation of air around the electronic cards prevents the formation of hot spots.

This kit is mounted on the upper part of the drive. It is powered by the drive.

The kit consists of:

- a fan subassembly
- mounting accessories

For drives	Reference	Weight kg
ATV 38HU18N4, HU29N4, HU41N4	VW3 A58822	0.450
ATV 38HU54N4, HU72N4, HU90N4	VW3 A58823	0.450
ATV 38HD12N4, HD16N4, HD23N4	VW3 A58824	0.500
ATV 38HD25N4, HD28N4, HD33N4, HD46N4	VW3 A58825	1.200
ATV 38HD25N4X, HD28N4X, HD33N4X, HD46N4X		
ATV 38HD54N4, HD64N4, HD79N4	VW3 A58826	1.200
ATV 38HD54N4X, HD64N4X, HD79N4X		

NEMA type 1 kit (IP 21 protection for mounting outside a wall-fixing or floor-standing enclosure)

The kit permits the connection of cables conforming to the NEMA type 1 standard.

The kit will provide IP 21 protection if the drive is mounted directly on a wall and not inside a wall-fixing or floor-standing enclosure.

This kit is mounted on the lower part of the drive.

The kit consists of:

- a cover made up of two metal parts
- mounting accessories

For drives	Reference	Weight kg
ATV 38HU18N4, HU29N4, HU41N4	VW3 A58852	0.950
ATV 38HU54N4, HU72N4, HU90N4	VW3 A58853	1.000
ATV 38HD12N4, HD16N4	VW3 A58854	1.100
ATV 38HD23N4	VW3 A58855	1.100
ATV 38HD25N4, HD28N4, HD33N4, HD46N4	VW3 A58856	1.120
ATV 38HD54N4, HD64N4, HD79N4	VW3 A58857	3.200

Presentation

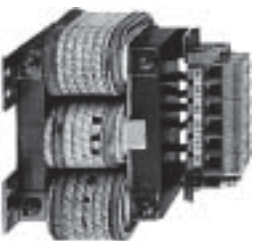

WV3 A6650p

Line chokes can be used to provide improved protection against overvoltages on the line supply and to reduce harmonic distortion of the current produced by the drive. The recommended chokes are used to limit the line current. The use of line chokes is recommended in particular under the following circumstances:

- b Line supply with significant interference from other equipment (interference, overvoltages)
- b Line supply with voltage imbalance between phases > 1.8% of the nominal voltage
- b Line with very low impedance (in the vicinity of power transformers 10 times more powerful than the drive rating)
- b Large number of frequency converters on the same line in order to reduce the line current
- b Use of cos φ correction capacitors or a power factor correction unit

ATTV 38HD25N4 (18.5 kW) to HD79N4 (75 kW) and HD25N4X (18.5 kW) to HD79N4X (75 kW) drives have a built-in line choke which limits the line current to the value of the nominal current of the motor.



WV3 A6850p

Characteristics

Conformity to standards

WV3 A66501 to WV3 A66503	WV3 A66504	WV3 A6850p
EN 50178 (VDE 0160 level 1 high energy overvoltages on the line supply)		IEC 60076 (with HD 398)

Voltage drop

Choke	IP 00	IP 00	IP 00
Terminals	IP 20	IP 10	-

Between 3 and 5% of the supply voltage. Values higher than this will cause loss of torque.

References

Drive

Prospective line lsc	Line current without choke at 400 V	Line current with choke	Choke Value of the choke	Nominal current	Loss	Reference	Weight
kA	A	A	mH	A	W		kg

3-phase supply voltage: 380 V - 10%...460 V + 10%

ATTV 38HU18N4	5	3.1	1.8	10	4	45	WV3 A66501	1,500
ATTV 38HU29N4	5	5.4	3.3	10	4	45	WV3 A66501	1,500
ATTV 38HU41N4	5	7.3	4.8	4	10	65	WV3 A66502	3,000
ATTV 38HU54N4	5	10	6.4	4	10	65	WV3 A66502	3,000
ATTV 38HU72N4	5	12.3	8.3	4	10	65	WV3 A66502	3,000
ATTV 38HU90N4	5	16.3	11.6	2	16	75	WV3 A66503	3,500
ATTV 38HD12N4	22	24.3	15.4	2	16	75	WV3 A66503	3,500
ATTV 38HD16N4	22	33.5	22.7	1	30	90	WV3 A66504	6,000
ATTV 38HD23N4	22	43.2	29.4	1	30	90	WV3 A66504	6,000
ATTV 38HD25N4p (1)	22	-	-	-	-	-	-	-
ATTV 38HD28N4p (1)	22	-	-	-	-	-	-	-
ATTV 38HD33N4p (1)	22	-	-	-	-	-	-	-
ATTV 38HD46N4p (1)	22	-	-	-	-	-	-	-
ATTV 38HD54N4p (1)	22	-	-	-	-	-	-	-
ATTV 38HD64N4p (1)	22	-	-	-	-	-	-	-
ATTV 38HD79N4p (1)	22	-	-	-	-	-	-	-
ATTV 38HC10N4X	22	-	156 (2)	0.220	160	220	WV3 A68501	35,000
ATTV 38HC13N4X	22	-	191 (2)	0.155	195	220	WV3 A68502	35,000
ATTV 38HC15N4X	22	-	229 (2)	0.120	235	220	WV3 A68503	40,000
ATTV 38HC19N4X	22	-	279 (2)	0.098	280	245	WV3 A68504	50,000
ATTV 38HC23N4X	22	-	347 (2)	0.066	365	270	WV3 A68505	50,000
ATTV 38HC25N4X	22	-	384 (2)	0.049	455	270	WV3 A68506	55,000
ATTV 38HC31N4X	22	-	433 (2)	0.038	540	280	WV3 A68507	60,000
ATTV 38HC33N4X	22	-	-	-	-	-	-	-

(1) The line choke is integrated into these drives.

(2) The addition of a line choke is recommended in particular for these drive ratings. The current values given include the addition of a line choke.

Variable speed drives for asynchronous motors Altivar 38

Radio interference input filters

Presentation



VW3 A68403



VW3 A68465

Function

b Note about built-in filters:
ATV 38HU18N4 to HD79N4 drives have a built-in radio interference filter to meet EMC "product" standards for speed drives IEC 1800-3 and EN 61800-3. Compliance with these standards is sufficient to meet the requirements of the European EMC (electromagnetic compatibility) directive.

b Additional input filters:
The additional radio interference input filters enable the drives to meet more stringent requirements.

These filters are designed to reduce emissions conducted on the line supply below the limits of standards EN 55011 class A or EN 55022 class B. They can be added to the following drives:

- v ATV 38HU18N4 to ATV 38 D23N4 which already have a built-in filter, if the motor cable is more than 5 m long,
- v ATV 38HD25N4p to ATV 38 D79N4p (1), available with or without built-in filters, if the motor cable is more than 25 m long,
- v ATV 38HC10N4X to ATV 38HC33N4X without built-in filters.

Additional input filters should be installed on the line supply, upstream of the drive, if the surrounding environment is subject to electromagnetic interference and radio-electric frequencies above 150 KHz.

VW3 A58402 to VW3 A58408 filters can be installed on ATV 38Hpppp drives. They act as supports for the drives and are fixed to them via tapped holes. VW3 A68401 to VW3 A68403 and VW3 A68415, A68435 and A68465 filters should be installed next to the drives.

The motor cables should be shielded and not exceed the maximum length given in the reference table.
For the filter to operate efficiently, the installation conditions must be carefully respected.

Use according to the type of mains supply

The **built-in filters** are compatible with IT connection (impeding or isolated neutral) up to 460 V. They help to attenuate interference even in conditions not defined by the EMC standard.

These **additional input filters** may only be used on TN (connected to neutral) and TT (neutral to earth) type supplies. They are not permitted on IT (impedance or isolated neutral) supplies.

(1) If EMC conformance is not required, replace p with an X in the drive reference.

Characteristics

Filters	VW3 A5840p	VW3 A684pp
Conformity to standards	EN 133200	
Degree of protection	IP 21 and IP 41 on upper part	IP 00
Maximum relative humidity	93% without condensation or dripping water conforming to IEC 60068-2-3	0...+45, up to +55 with current derating of 2% per °C above 45°C
Maximum operating temperature	-10...+60	
	Operation	Storage
Maximum operating altitude	Without derating	Without derating
	°C	°C
	-25...+70	-25...+70
	m	m
	1000 (above this, derate the current by 1% per additional 100 m)	

Variable speed drives for asynchronous motors Altivar 38

Radio interference input filters

Reference	Filters		Nominal filter current	Reference	Weight	
	Maximum length of motor cable ⁽¹⁾ EN 55011 class A m	EN 55022 class B m				A
3-phase supply voltage: 380 V - 10%...460 V + 10% 50-60Hz						
ATV 38HU18N4, HU29N4, HU41N4	50	20	25	VW3 A58402	3,600	
ATV 38HU54N4, HUR2N4, HU90N4	50	20	25	VW3 A58403	5,000	
ATV 38HD12N4, HD16N4	50	20	45	VW3 A58404	10,000	
ATV 38HD23N4	50	20	45	VW3 A58405	13,000	
ATV 38HD25N4	200	100	50	VW3 A58406	13,000	
ATV 38HD25N4X	50	20	50	VW3 A58406	13,000	
ATV 38HD28N4	200	100	50	VW3 A58406	13,000	
ATV 38HD28N4X	50	20	50	VW3 A58406	13,000	
ATV 38HD33N4, HD46N4	200	100	80	VW3 A58407	13,000	
ATV 38HD33N4X, HD46N4X	50	20	80	VW3 A58407	13,000	
ATV 38HD54N4, HD64N4, HD79N4,	200	100	160	VW3 A58408	20,000	
ATV 38HD54N4X, HD64N4X, HD79N4X	50	20	160	VW3 A58408	20,000	
For drives						
	Maximum length of motor cable ⁽¹⁾	Without motor choke	Nominal filter current	Loss	Reference	Weight
	With motor choke	choke	A	W		kg
	m	m				
Supply voltage: 400 V (± 15%)						
ATV 38HC10N4X	120	40	170	20	VW3 A68401 (2)	5,000
ATV 38HC13N4X and HC15N4X	150	40	300	40	VW3 A68402 (2)	5,500
ATV 38HC19N4X	100	40	300	40	VW3 A68402 (2)	5,500
ATV 38HC23N4X, HC25N4X, HC28N4X, HC31N4X et HC33N4X	120	40	570	60	VW3 A68403 (2)	6,000
Supply voltage: 440 V...460 V (± 15%)						
ATV 38HC10N4X	100	25	180	38	VW3 A68415	6,500
ATV 38HC13N4X, HC15N4X et HC19N4X	120	25	320	40	VW3 A68435	10,500
ATV 38HC23N4X, HC25N4X, HC28N4X, HC31N4X et HC33N4X	100	25	600	65	VW3 A68465	11,000

⁽¹⁾ The length of the shielded cables connecting the motor to the drive is limited. If motors are connected in parallel, it is the total length that should be taken into account. The limits are given as examples only as they vary depending on the interference capacity of the motors and the cables used.

ATV 38HU18N4 to ATV 38HD79N4p drives: cable length limits given for a switching frequency between 0.5 and 12 kHz.

ATV 38HC10N4X to ATV 38HC33N4X drives: cable length limits given for a modulation frequency of 2.5 kHz. They should be multiplied by 0.6 for a frequency of 5 kHz and by 0.3 for 10 kHz. If the motor cable is longer, the addition of a motor choke enables the length to be multiplied by 2.5, and the use of a single cable with a larger cross-section instead of several cables in parallel enables it to be multiplied by 1.5 or 2 if it is not shielded. In this case the radiated emissions are not limited.

⁽²⁾ Filters VW3 A68401 to 403 have 2 parts: the line choke should be mounted between them.

Variable speed drives for asynchronous motors

Ativar 38
Options: output filters and motor chokes

Presentation

By inserting an output filter between the drive and the motor, it is possible to:

- ↳ limit dV/dt to 500 V/ μ s at 400 V,
 - ↳ limit overvoltages to on the motor terminals to 1000 V at 400 V,
 - ↳ filter interference caused by opening a contactor placed between the filter and the motor,
 - ↳ reduce the motor earth leakage current.
- The offer comprises three types of filters and motor chokes.

Principle

LR filter cell
This cell comprises 3 high frequency chokes and 3 resistors.

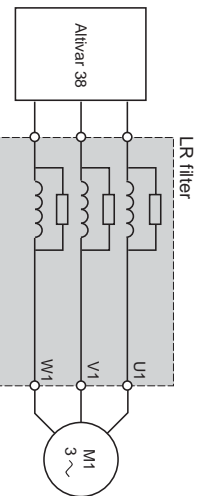

LC filter cell

This cell comprises 3 high frequency chokes and 3 capacitors.

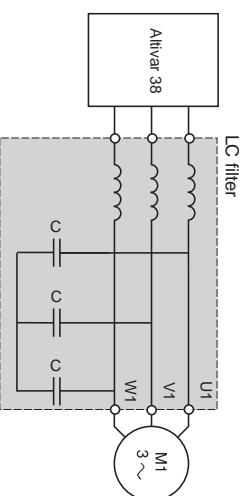

Chokes + capacitors combination

This combination comprises 3 capacitors installed in a delta connection in a junction box to be connected to a VW3 A6650P 3-phase line choke.

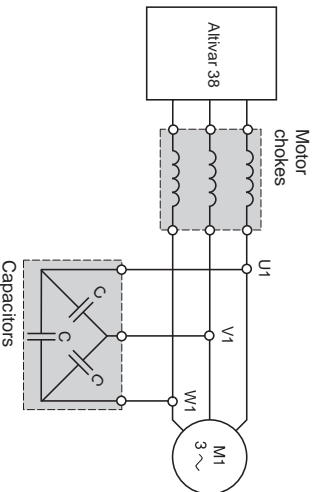

Motor choke

Overvoltages on the motor terminals can be limited by inserting an output choke between the drive and the motor. This is recommended for motor cable lengths over:

- 50 m (shielded cables) or 100 m (unshielded cables) for ATV 38HU18N4 to ATV 38HD79N4p drives,
- 50 m (shielded cables) or 80 m (unshielded cables) for ATV 38HC10N4X to ATV 38HC33N4X drives.

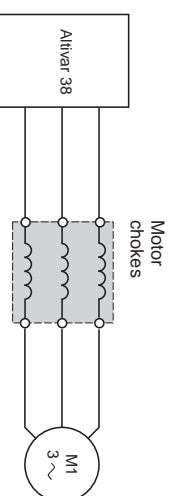

Characteristics (1)

Drive switching frequency	LR filter cells (2)		LC filter cells		Chokes + capacitors combinations		Motor chokes	
	kHz	VW3 A6641P	2 or 4	12	2 or 4	12	VW3 A6650P	VW3 A6855P
Length of motor cable	Shielded cables	m	y 100	y 40	y 20	y 100	y 50	y 100
		Unshielded cables	m	y 80	y 40	y 100	y 200	y 100
Degree of protection	Shielded cables	IP 20	IP 00	IP 00	IP 00	IP 00	IP 00	IP 20
		Unshielded cables	IP 20	IP 00	IP 00	IP 00	IP 00	IP 20

(1) Filter performance is ensured if the cable lengths between the motor and the drive given in the above table are not exceeded. If motors are connected in parallel, it is the total length that should be taken into account. If a cable longer than that recommended is used, the filters may overheat.

(2) For frequencies greater than 4 kHz or cable lengths longer than 100 m, please consult your Regional Sales Office.

Variable speed drives for asynchronous motors

Ativar 38

Options: output filters and motor chokes

LR filter cells		Nominal current	Loss	Reference	Weight
For drives		A	W		kg
ATTV 38HU18N4 to HU72N4		10	150	VW3 A58451	7.400
ATTV 38HU90N4		16	180	VW3 A58452	7.400
ATTV 38HD12N4 to HD23N4		33	220	VW3 A58453	12.500

LC filter cells		Reference	Weight
For drives			kg
ATTV 38HD25N4 to HD33N4		VW3 A66412	35.000
ATTV 38HD25N4X to HD33N4X		VW3 A66413	40.000

ATTV 38HD25N4 to HD46N4		VW3 A66506	16.000
ATTV 38HD25N4X to HD46N4X		VW3 A66421	0.250
ATTV 38HD54N4 to HD79N4		VW3 A66507	45.000
ATTV 38HD54N4X to HD79N4X		VW3 A66421	0.250

Chokes ⁽¹⁾ + capacitors combination

For drives	Description	Reference	Weight
			kg
ATTV 38HD25N4 to HD46N4	Motor chokes	VW3 A66506	16.000
ATTV 38HD25N4X to HD46N4X	Capacitors (2)	VW3 A66421	0.250
ATTV 38HD54N4 to HD79N4	Motor chokes	VW3 A66507	45.000
ATTV 38HD54N4X to HD79N4X	Capacitors (2)	VW3 A66421	0.250

Motor chokes

For drives	Reference	Weight
		kg
ATTV 38HD23N4 to HD46N4	VW3 A66506	16.000
ATTV 38HD25N4X to HD46N4X	VW3 A66507	45.000

For drives	Maximum length of motor cable ⁽³⁾		Nominal current	Max. loss	Reference	Weight
	unshielded	shielded				
	m	m	A	W		kg
Power supply voltage 400 V ± 15%						
ATTV 38HC10N4X 250	150	170	500		VW3 A68551	11.500
ATTV 38HC13N4X 300	200	300	650		VW3 A68552	18.000
ATTV 38HC15N4X 300	200	300	650		VW3 A68552	18.000
ATTV 38HC19N4X 250	150	300	650		VW3 A68552	18.000
ATTV 38HC23N4X 300	250	580	800		VW3 A68553	40.000
ATTV 38HC25N4X 300	250	580	800		VW3 A68553	40.000
ATTV 38HC31N4X 250	200	580	800		VW3 A68553	40.000
ATTV 38HC33N4X					VW3 A68553	40.000
Power supply voltage 440 V - 10%...460 V +10%						
ATTV 38HC10N4X 200	150	170	500		VW3 A68551	11.500
ATTV 38HC13N4X 250	200	300	650		VW3 A68552	18.000
ATTV 38HC15N4X 250	200	300	650		VW3 A68552	18.000
ATTV 38HC19N4X 200	150	300	650		VW3 A68552	18.000
ATTV 38HC23N4X 280	200	580	800		VW3 A68553	40.000
ATTV 38HC25N4X 250	200	580	800		VW3 A68553	40.000
ATTV 38HC28N4X					VW3 A68553	40.000
ATTV 38HC31N4X 220	180	580	800		VW3 A68553	40.000
ATTV 38HC33N4X					VW3 A68553	40.000

⁽¹⁾ It is not recommended to connect option VW3 A66421 to drive terminals without chokes as this could cause a drive fault to be displayed.

⁽²⁾ Connected to terminals S1, S2, S3 of the selected choke using wires with a cross-section of 1.5 mm².

⁽³⁾ For longer cables, please consult your Regional Sales Office.

Choke performance is ensured if the cable lengths above are not exceeded. If motors are connected in parallel, it is the total length that should be taken into account. If a cable longer than that recommended is used, the motor chokes may overheat.

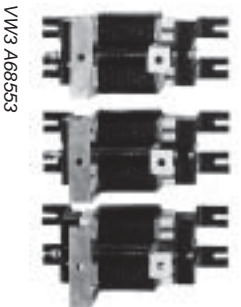

VW3 A68553

Variable speed drives for asynchronous motors

Altivar 38

Options: I/O extension cards, customer-specific cards

Presentation

I/O extension cards

The Altivar 38 drive can be specially adapted to suit certain types of application by installing an I/O extension card in the drive. Two models are available:

p Card with analogue input

Includes two C 24 V logic inputs, one C 24 V open collector logic output, one 0/20 mA analogue output and one bipolar ± 10 V analogue input. The analogue input can be used for speed correction with a tachogenerator, for feedback of the PI function, for processing of PTC motor protection probes or for summing the frequency reference.

p Card with encoder inputs

Includes two C 24 V logic inputs, one C 24 V open collector logic output, one 0/20 mA analogue output and A+, A-, B+, B- inputs which can be used for speed correction with an incremental encoder (Telemecanique XCC-H for example) or with an inductive or photoelectric sensor.

Customer-specific cards

To meet the requirements of special applications for which neither the standard product nor I/O extension cards are suitable, we can design and supply cards on request which incorporate:

- hardware functions (I/O),

- software functions (special cycles and servo controls, etc).

Cards are already available for:

p Pump switching card

This is used for controlling a complete pumping or compression installation using a single Altivar 38, and

provides:

- constant pressure in the supply, regardless of flow rate,

- ease of setup and diagnosis of the installation, using the Altivar 38,

- control of a variable speed pump and up to 4 fixed speed pumps, avoiding systematic wear of the same pumps. For more information, please consult your Regional Sales Office.

p Multimotor card

Has 2 C 24 V reassignable logic inputs, 1 C 24 V open collector logic output, one 0/20 mA analogue output, and one bipolar ± 10 V analogue input. The analogue input can be used for speed correction with a tachogenerator, for feedback of the PI function, for processing of PTC motor protection probes, or for summing the frequency reference.

Two drive configurations can be switched when the motor is stopped.

Functions:

Loading two configurations with an Altivar 38 operator dialogue terminal, switching configurations via logic input or with an operator dialogue terminal, automatic auto-tuning possible after switching.

p Multiparameter card

This is used to switch (automatically or via logic input) up to 16 sets of 13 parameters, 6 of which are pre-defined and 7 are user-definable. Only the adjustment functions are taken into account when the motor is running.

p Simple position indexer card

This is used to define a cycle which manages the motion of a moving part along an axis with a limit switch as the end stop preceded by another end stop imposing the change to low speed.

Positioning can be performed in both directions:

- forward,

- reverse.

The card is equipped with:

- 6 logic inputs C 24 V,

- 1 logic output C 24 V with open collector,

- 1 bipolar analogue input ± 10 V,

- 1 analogue output 0-20 mA.

The Altivar 38 is designed to take a card mounted in the I/O extension card slot.

These special cards are for use with standard machines. Please consult your Regional Sales Office for a quotation.

Characteristics of I/O extension cards

Internal sources available	Protected against short circuits and overloads - 1 output + 10 V \pm 1 %, maximum flow rate 10 mA - 1 output - 10 V \pm 1 %, maximum flow rate 10 mA - 1 output + 24 V (min. 20 V, max. 30 V), maximum flow rate 200 mA for all 24 V drive outputs
LI logic inputs	Assignable logic inputs, impedance 3.5 k Ω , compatible with level 1 PLC, IEC standard 65A-68 Maximum length of shielded cable: 100 m Power supply + 24 V (min. 12 V, max. 30 V), Status 0 if < 5 V, status 1 if > 11 V Sampling time 2 ms max.
LO logic output	Assignable open collector logic output, compatible with level 1 PLC, IEC standard 65A-68 Power supply + 24 V (min. 12 V, max. 30 V), max. current 20 mA with internal source and 200 mA with external source Sampling time 2 ms max.
AO analogue output	Assignable logic output 0/20 mA, max. load impedance 500 Ω (reassignable to X-YmA, by programming X and Y from 0 to 20 with a definition of 0.1 mA) Resolution 0.04 mA (9 bits), linearity \pm 0.1 mA, precision \pm 0.2 mA Sampling time 2 ms max.
AI analogue input	1 assignable differential bipolar input 0 \pm 10 V, impedance 30 k Ω . Adjustable gain Frequency reference resolution: 0.1 Hz for 100 Hz (10 bits plus sign) Precision \pm 0.5 %, linearity \pm 0.2 %, of max. output frequency Sampling time 2 ms max. Max. length of shielded cable: 20 m If configured for PTC probe processing, use at 750 Ω max. at 20 °C (3 x 250 Ω probes in series)
or	For encoders or detectors with NPN-type open collector outputs, nominal voltage 24 V C (19.2 at 30 V) Input impedance 785 Ω \pm 10 % Max. signal frequency 33 kHz at max. speed HSP We recommend the use of an external 24 V source when using the drive with incremental coders

I/O extension cards

Description	For drives	Reference	Weight kg
Card with analogue input	ATV-38 all ratings	VW3-A58201	0.200
Card with encoder inputs	ATV-38 all ratings	VW3-A58202	0.200

Customer-specific cards

Description	For drives	Reference	Weight kg
Pump switching card	ATV-38 all ratings	VW3-A58210	0.200
Multimotor card	ATV-38 all ratings	VW3-A58211	0.200
Multiparameter card	ATV-38 all ratings	VW3-A58212	0.200
Simple position indexer card	ATV-38 all ratings	VW3-A58213	0.200

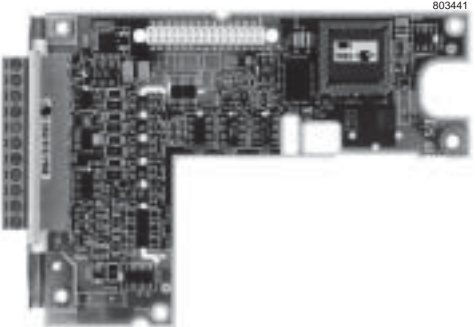

803441
VW3-A5820p

Variable speed drives for asynchronous motors Altivar 38

Communication option

Presentation

The Altivar 38 can be connected to the communication networks or buses via communication cards or gateways.
Communication cards are available for the following buses or networks:

- b Fipio
- b Modbus Plus
- b Uni-Telway, Modbus ASCII, Modbus RTU/Jbus
- b Interbus-S
- b AS-i
- b Profibus DP
- b Ethernet
- b CANopen
- b DeviceNet
- b METASYS N2

Communication gateways are available for the Profibus DP bus and the LonWorks network.

Functions

Cards for Fipio, Modbus Plus, Uni-Telway/Modbus, Interbus-S, Profibus DP, Ethernet, CANopen, DeviceNet, METASYS N2 bus or network

- Using these communication cards will enable you to benefit from the entire range of functions offered by the Altivar 38 :
- b **Configuration** (accessible in read and write modes): line supply frequency, motor voltage, ramp profile, I/O assignment, etc.
 - b **Adjustment** (accessible in read and write modes): d.c. injection time and amplitude, thermal protection, speed range, ramp time, current limitation, etc.
 - b **Control** (accessible in read and write modes): run/stop, braking, frequency reference, fault reset, etc.
 - b **Signalling** (accessible in read only mode): drive status register, motor speed, motor current, logic I/O status register, fault register, etc.
 - b **Authorisation** of local control (via the terminals)

Card for the AS-i bus

- Using this communication card will enable you to benefit from the entire range of functions offered by the Altivar 38 :
- b **Control**: run/stop, braking, frequency reference (preset values), fault reset, +/- speed
 - b **Signalling**: drive status (ready, running, faulty, frequency reference reached, thermal threshold reached, local forcing)
 - b **Authorisation** of control via the terminals (local forcing)

Characteristics	Bus or network	Maximum number of drives controlled on the bus	Transmission speed
Fipio		62	1 Mbps
Modbus Plus		64	1 Mbps
Uni-Telway, Modbus ASCII, Modbus RTU/Jbus		31	4800...19,200 bps
Interbus-S		64	1 Mbps
AS-i		31	166 Kbps
Profibus DP	with card	126	9600 bps ...12 Mbps
	with gateway	15 Modbus + 126 Profibus DP	9600 bps ...12 Mbps
Ethernet		–	10/100 Mbps
CANopen		63	125/250/500/1000 Kbps
DeviceNet		63	125/250/500 Kbps
METASYS N2		255	–
LonWorks		2	78 kbps

Variable speed drives for asynchronous motors Altivar 38

Communication options

Communication card

For bus or network

Reference	Weight kg
-----------	--------------

FiPo: The card is equipped with a male 9-way SUB-D connector, which will take a TSX FP ACC 12 removable connector with TSX FP CCpp connecting cable or TSX FP CApp tap cable. The card is used for read/write access to all functions via the application program of the PLC.	VW3 A58311	0.300
--	------------	-------

Modbus Plus: The card is equipped with a female 9-way SUB-D connector, which can take a Modbus Plus drop cable with connectors, reference 990NAD21110 or 990NAD21130. This cable should be connected to a Modbus Plus tap, reference 990NAD23000, for connection to the Modbus Plus trunk cable, reference 490NAA271pp.	VW3 A58302	0.300
--	------------	-------

Uni-Telway/Modbus: The card is equipped with a female 9-way SUB-D connector and supplied with a 3 m cable fitted with a male 9-way SUB-D connector and a male 15-way SUB-D connector for connection on TSX SCA 62 subscriber sockets.	VW3 A58303	0.300
--	------------	-------

Interbus-S: The card is equipped with one male and one female 9-way SUB-D connector for connection with cables with connectors and 2 screw terminals for separate C 24 V supplies. Power supply: C 24 V, 200 mA min., to be ordered separately.	VW3 A58304E	0.300
--	-------------	-------

AS-i: The card is equipped with removable terminals. Example of connection accessory: use a tap-off for the AS-i cable, reference XZ-CG0122.	VW3 A58305	0.300
---	------------	-------

Profibus DP: The card is equipped with a female 9-way SUB-D connector for connection to cables with connectors.	VW3 A58307	0.300
--	------------	-------

Ethernet: The card is equipped with an RJ 45 connector for connection to cables with connectors, reference 490NTW000pp.	VW3 A58310	0.300
--	------------	-------

CANopen: The card is equipped with removable screw terminals.	VW3 A58308	0.300
--	------------	-------

VW3 A58310

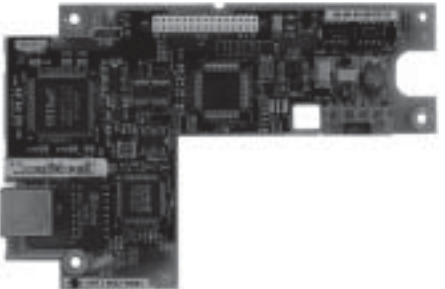

DeviceNet: The card is equipped with removable screw terminals. The card supports: b The ODVA (Open Device Vendor Association) profile b The drive profile defined previously.	VW3 A58309	0.300
--	------------	-------

METASYS N2: The card is equipped with a female 9-way SUB-D connector.	VW3 A58354U	0.300
--	-------------	-------

Communication module and gateway

For bus or network

Reference	Weight kg
-----------	--------------

LonWorks: The module is equipped with a removable 5-way screw connector for the network (1). The LonWorks module is connected either on the Modbus VW3 A58303 card via a cable supplied with the module, or on the drive terminal port. If the LonWorks module is connected on the drive terminal port, it will not be possible to use the operator terminal.	VW3 A58312PU	0.300
--	--------------	-------

Profibus DP: The gateway is equipped with an RJ 45 connector for connection to a cable fitted with connectors, reference VW3 P07306R10, and a 9-way SUB-D connector for connection to a stripped cable, reference VW3 A8306D30 (1).	LA9 P307	-
--	----------	---

(4) The module or gateway must be powered with a C 24 V supply. Power supply C 24 V, 140 mA min., to be ordered separately.

Nota : To order connection cables and accessories, please consult our "Premium Automation Platform" and "Micro Automation Platform" specialist catalogues or the manufacturers' catalogues.

PowerSuite advanced dialogue solutions

The PowerSuite advanced dialogue solutions can be used for Schneider Electric drives and starters. They enable communication with the product from a Pocket PC, a PC or a dedicated terminal.

The solutions, with a Pocket PC or PC, enable files to be prepared for uploading to the drives and the starters. The PowerSuite software creates its files ensuring consistency between the configuration/adjustment functions of the product.

PowerSuite Pocket PC

The Pocket PC can be used during preparation, programming, setup and maintenance.

It comprises a Pocket PC terminal and corresponding connection accessories. The software is integrated into a Windows CE environment, for which the operating system language can be selected on ordering (English, French, German, Spanish, Italian).

The software incorporates all the functions of integrated and remote terminals (drive or starter configuration and adjustment, control, signalling, etc).

The Pocket PC can be used:

- ↳ alone to prepare and store configuration/adjustment files (integral battery or line supply)
- ↳ connected to a PC for uploading configuration/adjustment files from the Pocket PC to the PC or downloading from the PC to the Pocket PC
- ↳ connected to the drive or to the starter for configuration, adjustment or control purposes or to upload a configuration/adjustment file from the Pocket PC to the product or download a configuration/adjustment file from the product to the Pocket PC.

502945

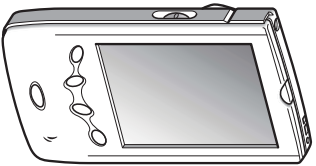

510086

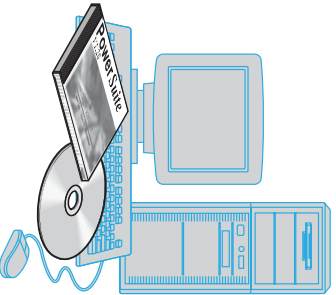

PowerSuite software workshop for PC

The PowerSuite software workshop is used to set up a drive or a starter from a PC in a Microsoft Windows 95, 98, NT4 or 2000 environment.

The software incorporates all the functions of integrated and remote terminals (drive or starter configuration and adjustment, control, signalling, etc.) with assisted, guided operator dialogue in 5 languages (English, French, German, Spanish, Italian) in a Windows environment.

It can be used:
 ↳ alone to prepare and store drive or starter configuration files on diskette, CD-ROM or hard disk

The drive or starter configuration can be printed out on paper or can be exported to office automation software.

↳ connected to the drive or starter for configuration, adjustment or control purposes, or for uploading a configuration/adjustment file from the PC to the product or downloading from the product to the PC.

Connection is via a link between the drive or starter connector and the serial port on the PC.

510886

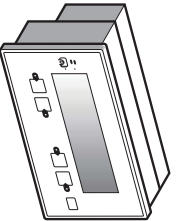

Magelis display unit with matrix screen

The Magelis display unit with matrix screen can be used to monitor, diagnose and adjust up to 8 Altivar 28, 38, 58 or 58F drives in 5 languages (English, French, German, Spanish, Italian). It can display variables in alphanumeric format with European, Cyrillic or Asian fonts in 4 sizes, or it can display icons or background images in black and white as well as animations in barchart or gauge format. The application is preloaded in the factory.

Compatibility

Compatibility of advanced dialogue solutions with drives and starters

		Drives			Starter	TeSys model U controller-starters
		ATV 28, ATV 58, ATV 58F	ATV 38	ATV 11		
PowerSuite Pocket PC						
Pocket PC	VW3 AB108pp	U V 1,20	U V 1,40	U V 1,40	U V 1,30	
Setup kit	VW3 AB102	U V 1,20	U V 1,40	U V 1,40	U V 1,30	
Connection kit	VW3 AB111					
PowerSuite software workshop for PC						
CD-ROM	VW3 AB104 r	U V 1,0	U V 1,40	U V 1,40	U V 1,30	U V 1,40
Connection kit	VW3 AB106					
Magelis display unit with matrix screen						
Display unit	XBT HM017010A8					
Accessories						
CD-ROM	VW3 AB105 r	U V 1,0	U V 1,40	U V 1,40	U V 1,30	U V 1,40
Operator terminal	VW3 AB103pp					

Incompatible products

Compatible products and versions

r V 1.40 software version available 2nd half 2002.

PowerSuite advanced dialogue solutions

520962



VW3 A8103pp

PowerSuite Pocket PC

Several solutions are available to meet the needs of individual users:

- the complete Pocket PC
- the setup kit
- the connection kit for Pocket PC.

The complete Pocket PC comprises:

- 1 "Jordana 525" Pocket PC, with multilingual operating system (1), supplied with PC synchronisation cable and mains power supply
- 1 CD-ROM containing the multilingual (1) setup software which can be ordered separately

The setup kit comprises:

- 1 CD-ROM containing the multilingual (1) setup software which can be ordered separately
- 1 connection kit for the Pocket PC

The connection kit for the Pocket PC comprises:

- 2 connection cables, length 0.6 m, with 2 RJ45 connectors
- 1 RJ45/9-way SUB-D adaptor for connecting ATV 38, ATV 58 and ATV 58F
- 1 converter marked "RS 232/RS 485 PPC" with one 9-way male SUB-D connector and 1 RJ45 connector.
- 1 converter, for ATV 11, with one 4-way male connector and 1 RJ45 connector.

Description	Reference	Weight kg
Complete Pocket PC	VW3 A8108pp (2)	1,000
Setup kit	VW3 A8102	0,400
Connection kit for the Pocket PC	VW3 A8111	0,300

PowerSuite software workshop for PC

The PowerSuite software comprises:

- 1 CD-ROM containing the multilingual (1) setup software
- 1 connection kit for PC

The PC connection kit comprises:

- 2 connection cables, length 3 m, with 2 RJ45 connectors
- 1 RJ45/9-way SUB-D adaptor for connection of ATV 38, ATV 58 and ATV 58F drives
- 1 converter marked "RS 232/RS 485 PC" with one 9-way female SUB-D connector and 1 RJ45 connector
- 1 converter, for ATV 11, with one 4-way male connector and 1 RJ45 connector.

Description	Reference	Weight kg
1 CD-ROM containing the multilingual setup software (1)	VW3 A8104 r	0,100
Connection kit for PC	VW3 A8106	0,350

Magelis display unit with matrix screen

The terminal has a backlit LCD with 8 lines of 40 characters.

The RS 485 connection kits for ATV 28 (VW3 A28301), ATV 38 and ATV 58 (VW3 A58306) drives, as well as other connection accessories, should be ordered separately according to the number and type of drives connected. Please consult your Regional Sales Office.

Description	Reference	Weight kg
Magelis display unit with matrix screen	XBT HM017010A8	0,600
Accessories	Reference	Weight kg
1 upgrade CD-ROM for multilingual (1) setup software (3)	VW3 A8105 r	0,100
"Jordana 525" Pocket PC terminal supplied with PC synchronisation cable and mains power supply	VW3 A8103pp (2)	0,300
1 x 16 MB compact flash card containing the Pocket PC software for the "Jordana 525" (4)	VW3 A8110	0,100

(1) English, French, German, Spanish, Italian.

(2) To order the operating system in your chosen language, replace pp by EN for English, FR for French, DE for German, SP for Spanish and IT for Italian.

(3) To find out about the latest available version, please consult your Regional Sales Office.

(4) This card enables the software to be run immediately without synchronising with a PC.

r V 1.40 software version available 2nd half 2002.

105080



XBT HM017010A8

Variable speed drives for asynchronous motors Ativar 38

ATV 38HU18N4 to ATV 38HD23N4

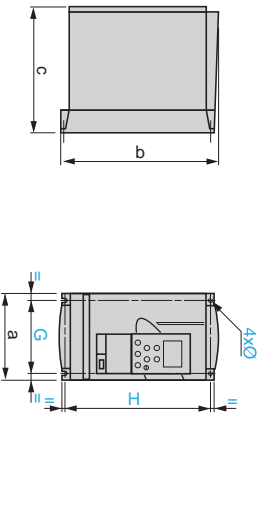

ATV 38H	a	b	c	G	H	Ø
U18N4, U23N4, U41N4	150	230	184	133	210	5
U54N4, U72N4, U90N4	175	286	184	155	270	5.5
D12N4, D16N4	230	325	210	200	310	5.5
D23N4	230	415	210	200	400	5.5

Maximum connection capacity: all terminals
ATV 38H

U18N4 to U90N4: 6 mm² (AWG 8)
D12N4 to D23N4: 10 mm² (AWG 6)

ATV 38HD25N4p to ATV 38HD79N4p

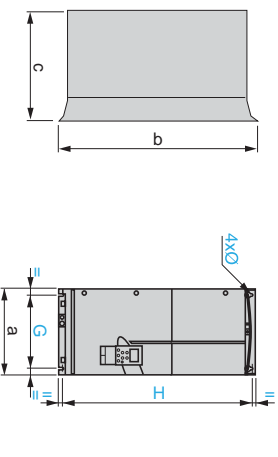

ATV 38H	a	b	c	G	H	Ø
D25N4p, D28N4p, D33N4p, D46N4p	240	550	283	205	530	7
D54N4p, D64N4p, D79N4p	350	650	304	300	619	9

Maximum connection capacity: all terminals
ATV 38H

D25N4p, D28N4p: 16 mm² (AWG 4)
D33N4p, D46N4p: 35 mm² (AWG 2)
D54N4p to D79N4p: 70 mm² (AWG 2/0)

ATV 38HC10N4X to ATV 38HC33N4X

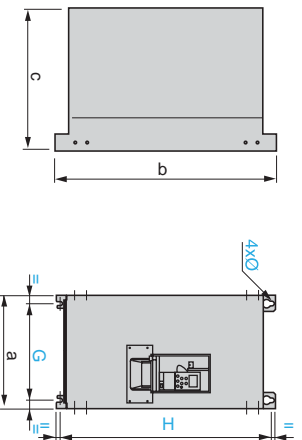

ATV 38H	a	b	c	G	H	Ø
C10N4X	370	630	360	317.5	609	12
C13N4X, C15N4X, C19N4X	480	680	400	426	652	12
C23N4X, C25N4X, C28N4X, C31N4X, C33N4X	660	950	440	598	920	15

Maximum connection capacity

ATV 38H	Earth connection	Power terminal
C10N4X to C15N4X	60 mm ²	100 mm ²
C19N4X	100 mm ²	150 mm ²
C23N4X to C25N4X	100 mm ²	200 mm ²
C28N4X to C33N4X	150 mm ²	150 x 2 mm ²

Control card fan kit

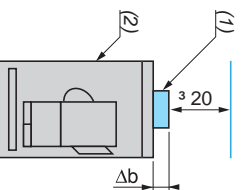

VW3	a	b
A58822	25	25
A58823	25	25
A58824	25	25
A58825	60	60
A58826	60	60

(1) VW3 A58822 to VW3 A58826
(2) Drive

NEMA type 1 kit

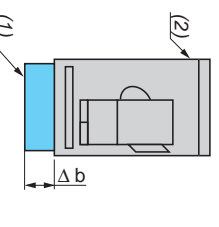

VW3	a	b
A58852	71	71
A58853	75	75
A58854	75	75
A58855	75	75
A58856	89	89
A58857	171	171

(1) VW3 A58852 to VW3 A58857
(2) Drive

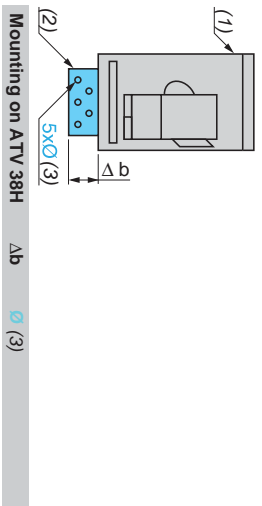

Mounting on ATV 38H	Δb	Ø (3)
U18N4 to U90N4	64.5	M4
D12N4 to D23N4	62	M4
D25N4p to D46N4p	80	M5
D54N4p to D79N4p	110	M5

(1) Drive
(2) Mounting plate
(3) Tapped holes for fixing the EMC clamps

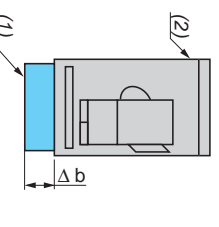

VW3	a	b
A58822	25	25
A58823	25	25
A58824	25	25
A58825	60	60
A58826	60	60

(1) VW3 A58822 to VW3 A58826
(2) Drive

Variable speed drives for asynchronous motors Altivar 38

3-phase chokes (line and motor) VW3 A66501 to VW3 A66507

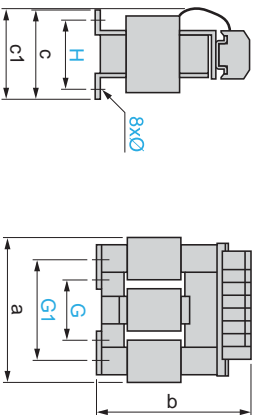

VW3	a	b	c	c1	G	G1	H	Ø
Line chokes								
A66501	100	135	55	60	40	60	42	6 x 9
A66502	130	155	85	90	60	80.5	62	6 x 12
A66503	130	155	85	90	60	80.5	62	6 x 12
A66504	155	170	115	135	75	107	90	6 x 12
Motor chokes								
A66506	275	210	130	160	105	181	100	11 x 22
A66507	320	290	172	215	190	230	142	-

3-phase line chokes VW3 A68501 to VW3 A68507

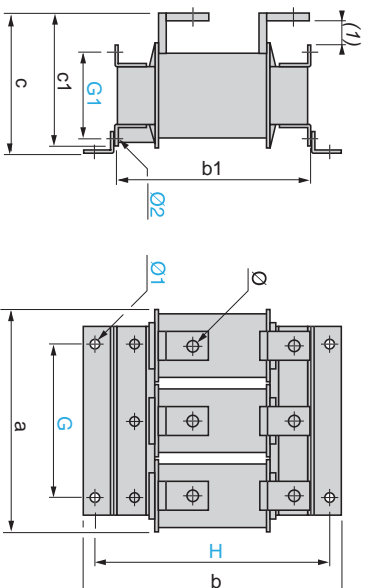

VW3	a	b	b1	c	c1	G	G1	H	Ø	Ø1	Ø2
A68501	280	305	240	210	200	200	125	275	9	9	9
A68502	280	330	260	210	200	200	125	300	11	9	9
A68503	320	380	300	210	200	225	150	350	11	9	9
A68504	320	380	300	210	200	225	150	350	11	9	9
A68505	320	380	300	250	230	225	150	350	13	11	11
A68506	320	380	300	250	230	225	150	350	13	11	11
A68507	320	380	300	250	230	225	150	350	13	11	11

(1) min. 25 mm

Radio interference suppression filters (EMC) VW3 A58402 to VW3 A58408

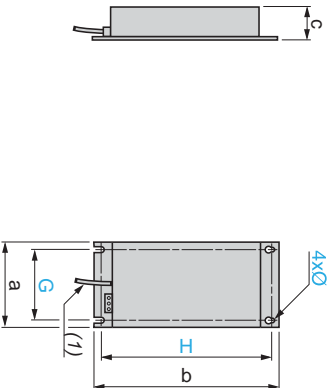

VW3	a	b	c	G	H	Ø
A58402	150	276	50	133	260	5
A58403	175	340	60	153	320	6
A58404	230	390	60	201	370	6
A58405	230	480	60	201	460	6
A58406	240	690	85	215	650	7
A58407	240	690	85	215	650	7
A58408	350	770	90	300	770	9

(1) Cable

VW3 A68401 (2 elements)

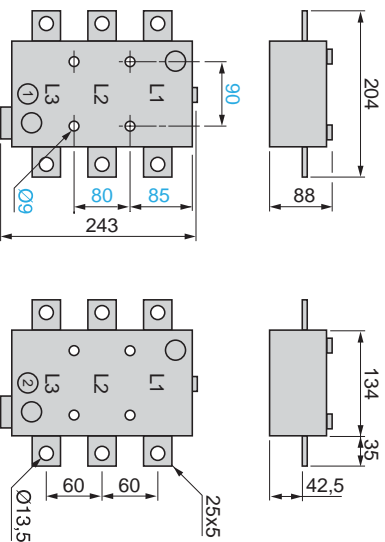

Variable speed drives for asynchronous motors Ativar 38

Radio interference suppression filters (EMC) (continued)
VW3 A68402, A68403 (2 elements)

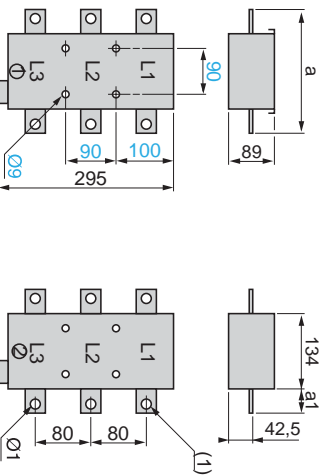

VW3	a	a1	Ø	(1)
A68402	204	35	11	bar 30 x 5
A68403	224	40	13.5	bar 40 x 5

VW3 A68415

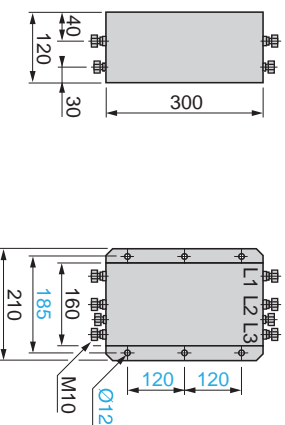

VW3 A68435 and A68465

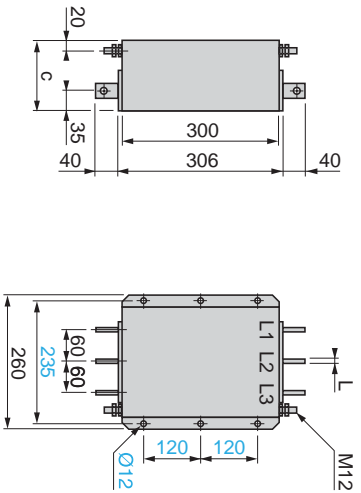

VW3	c	L
A68435	115	6
A68465	135	8

Output filters
VW3 A58451 to A58453

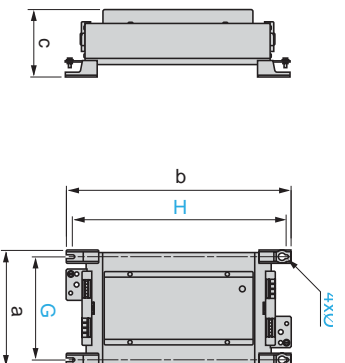

VW3	a	b	c	G	H	Ø
A58451	169.5	420	123	150	315	7
A58452	169.5	420	123	150	315	7
A58453	239	467.5	139.5	212	444	7

Additional motor chokes
VW3 A68551

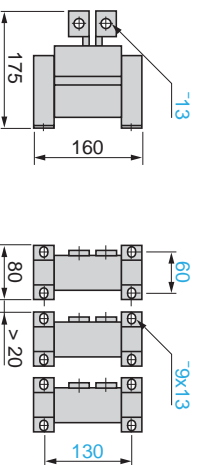

VW3 A68552

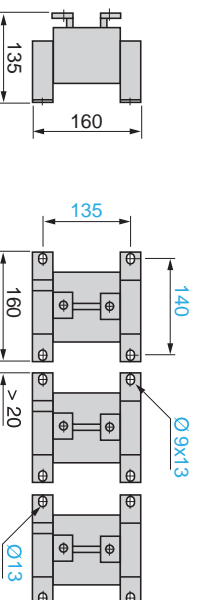

Additional motor chokes
VW3 A68553

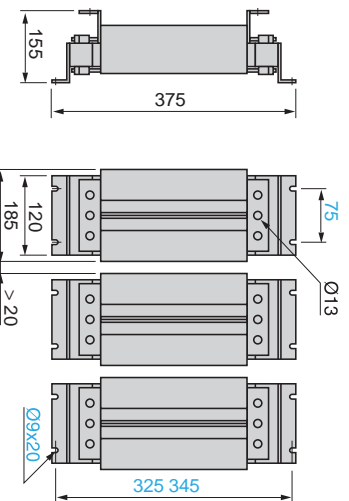

Mounting the remote operator terminal
VW3 A58103

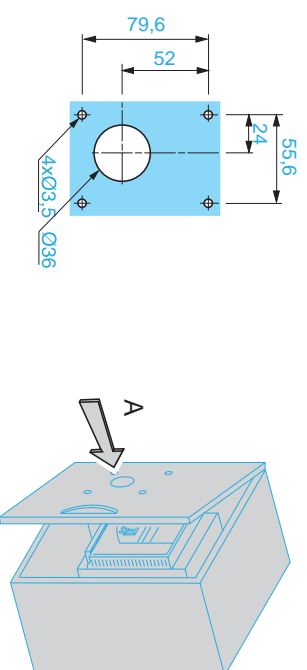

Variable speed drives for asynchronous motors Ativar 38

Mounting recommendations

Depending on the conditions in which the drive is to be used, its installation will require certain precautions and the use of appropriate accessories. Install the unit vertically, at $\pm 10^\circ$. Do not place it close to heating elements. Leave sufficient free space to ensure that the air required for cooling purposes can circulate from the bottom to the top of the unit.

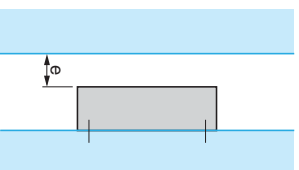
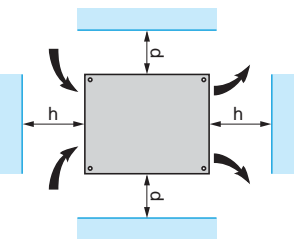

Drive	Mounting recommendations
ATV 38HU18N4 to ATV 38HU90N4	e u 10 mm, h u 50 mm -10...+40°C d u 50 mm, no special precautions d = 0 mm, remove the driver's protective blanking cover (the degree of protection will then be IP 20) +40...+50°C d u 50 mm, remove the driver's protective blanking cover (the degree of protection will then be IP 20) +50...+60°C d u 50 mm, add the VW3 A5882p control card fan kit. Derate the current by 2.2 % per °C above 50°C.
ATV 38HD12N4 to ATV 38HD23N4	e u 10 mm, h u 50 mm -10...+40°C d = 0 mm, no special precautions d = 0 mm, remove the driver's protective blanking cover (the degree of protection will then be IP 20) +40...+50°C d u 50 mm, remove the driver's protective blanking cover (the degree of protection will then be IP 20). Derate the current by 2.2 % per °C above 40°C. d = 0 mm, add the VW3 A5882p control card fan kit. Derate the current by 2.2 % per °C above 40°C.
ATV 38HD25N4p to ATV 38HD79N4p	e u 50 mm, h u 100 mm, d u 50 mm -10...+40°C, no special precautions +40...+50°C, add the VW3 A588pp control card fan kit. Derate the current by 2.2 % per °C above 40°C.
ATV 38HC10N4X to ATV 38HC33N4X	e u 50 mm, h u 100 mm, d u 50 mm -10...+40°C, no special precautions +40...+50°C, add the VW3 A588pp control card fan kit. Derate the current by 2.2 % per °C over 40°C.

Mounting in a metal wall-mounted or floor-standing enclosure with degree of protection IP 23 or IP 54

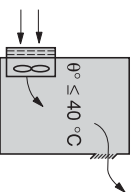
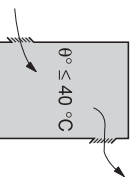

- b Observe the mounting recommendations above.
- b To ensure proper air circulation in the drive: fit ventilation grilles, ensure that the ventilation is adequate - if not, install forced ventilation with a filter.
- b Use special filters with IP 54 protection.

Fan flow rate depending on the drive rating

ATV 38 drive	Flow rate m ³ /hour
ATV 38HU18N4	not cooled
ATV 38HU29N4, HU41N4, U54N4	36
ATV 38HU72N4, HU90N4, HD12N4, HD16N4, HD23N4	72
ATV 38HD25N4p, HD28N4p, HD33N4p, HD46N4p	292
ATV 38HD54N4p, HD64N4p, HD79N4p	492
ATV 38HC10N4X	600
ATV 38HC13N4X, HC15N4X, HC19N4X	900
ATV 38HC23N4X, HC25N4X, HC28N4X, HC31N4X, HC33N4X	900

Metal wall-mounted or floor-standing enclosure with IP 54 degree of protection

The drive must be mounted in a dust and damp proof casing in certain environmental conditions: dust, corrosive gases, high humidity with risk of condensation and dripping water, splashing liquid, etc.

To avoid hot spots in the drive, add a fan to circulate the air inside the enclosure, reference VW3 A5882p (see page 10). This enables the drive to be used in an enclosure where the maximum internal temperature can reach 60°C.

Calculating the size of the wall-mounted or floor-standing enclosure

Maximum thermal resistance R_{th} (°C/W)

$$R_{th} = \frac{\theta - \theta_e}{P} \quad \theta = \text{maximum temperature inside the enclosure in } ^\circ\text{C}, \theta_e = \text{maximum external temperature in } ^\circ\text{C}, P = \text{total power dissipated in the enclosure in W}$$

Power dissipated by drive: see page 8. Add the power dissipated by the other equipment components.

Effective exchange surface area of enclosure S (m²)

(sides + top + front panel if wall-mounted)

$$S = \frac{K}{R_{th}} \quad K \text{ is the thermal resistance per m}^2 \text{ of casing}$$

For ACM type metal enclosures: K = 0,12 with internal fan, K = 0,15 without fan

Caution: Do not use insulated enclosures as they have a poor level of conductivity.

Scheme without line contactor, recommended for machines which are not dangerous

ATV 38Hpppp

3-phase power supply

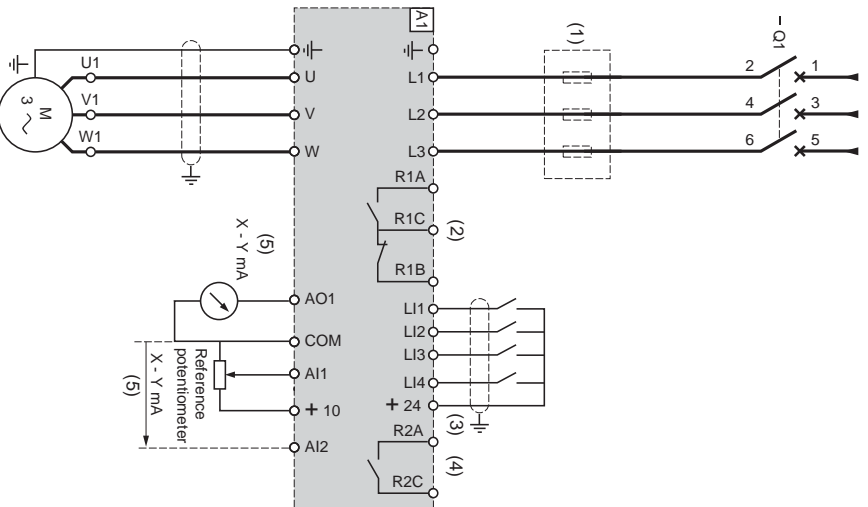

Scheme with line contactor, recommended for dangerous machines which are switched off and on infrequently

3-phase power supply

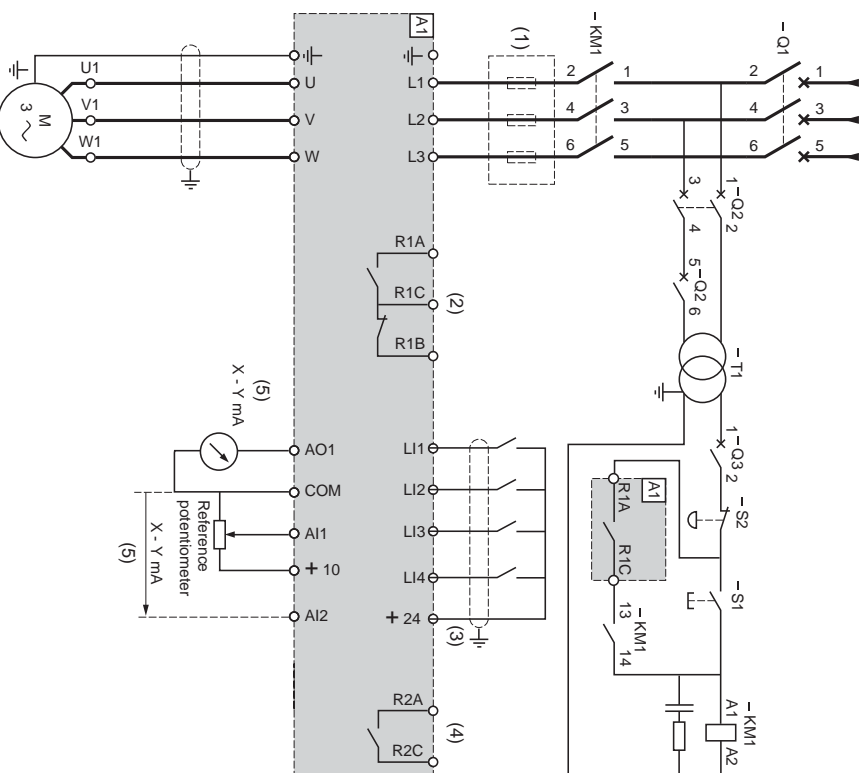

- (1) Line choke recommended
- (2) Fault relay contacts for remote signalling of drive status
- (3) Internal +24 V. If an external +24 V supply is used, connect the 0 V on the external supply to the COM terminal, do not use the +24 terminal on the drive, and connect the common of the LI inputs to the +24 V of the external supply.
- (4) Relay R2 can be reassigned
- (5) X and Y can be configured between 0 and 20 mA independently for AI2 and AO1.

Nota :

- 1 All terminals are located at the bottom of the drive.
- 2 Fit interference suppressors to all specific circuits near the drive or connected on the same circuit, such as relays, contactors, solenoid valves, fluorescent lighting, etc.

Compatible components

Code	Description
A1	Drive
Q1	GV2-L or Compact NS circuit-breaker (see pages 30 and 31)
KM1	LC1-Dpp contactor with interference suppressor (see pages 30 and 31)
S1, S2	XB2-B or XA2-B pushbuttons
T1	100 VA transformer 220 V secondary
Q2	GV2-L circuit-breaker rated at twice the nominal primary current of T1
Q3	GB2-CB05

Presentation:
pages 2 and 3

Characteristics:
pages 4 to 7

References:
page 8

Dimensions:
pages 22 to 25

Scheme with downstream contactor, recommended for dangerous machines which are switched off and on frequently

ATV 38HU18N4 to ATV 38HD23N4
3-phase power supply

ATV 38HD25N4p to ATV 38HC33N4p
3-phase power supply

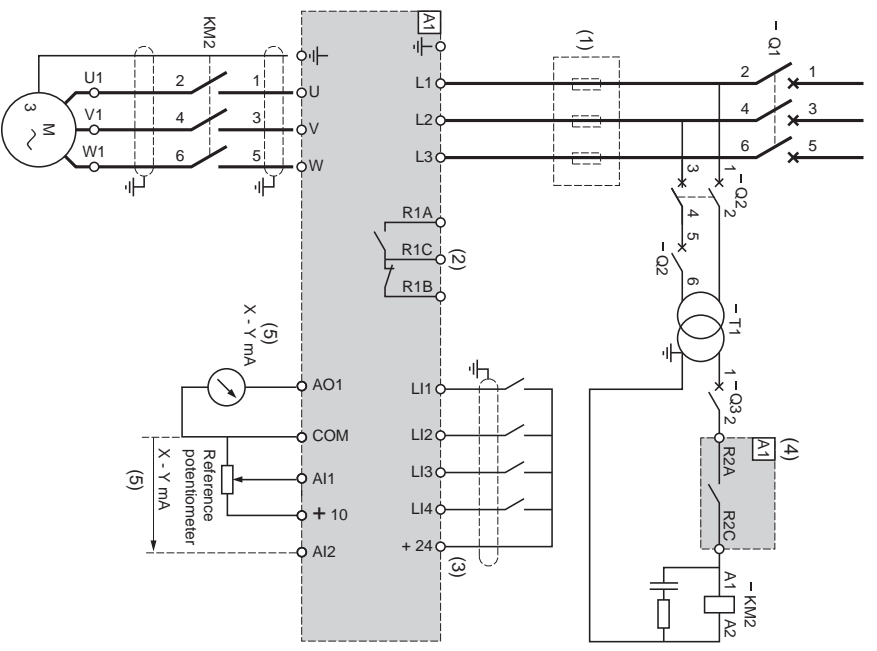
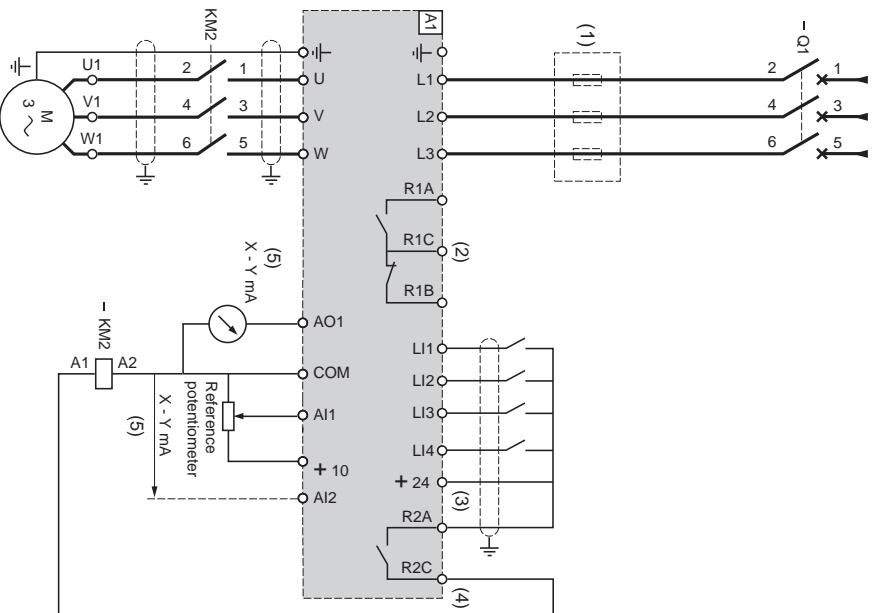

- Note :**
- 1 All terminals are located at the bottom of the drive.
 - 2 Fit interference suppressors to all specific circuits near the drive or connected on the same circuit, such as relays, contactors, solenoid valves, fluorescent lighting, etc.

Compatible components

Code	Description
A1	Drive
Q1	GV2-L or Compact NS circuit-breaker (see pages 30 and 31)
KM2	LC1-Dpp contactor with interference suppressor (see pages 30 and 31)
T1	100 VA transformer 220 V secondary
Q2	GV2-L circuit-breaker rated at twice the nominal primary current of T1
Q3	GB2-CB05

Variable speed drives for asynchronous motors

Ativar 38

External 24 V supply for the logic inputs and/or the logic output

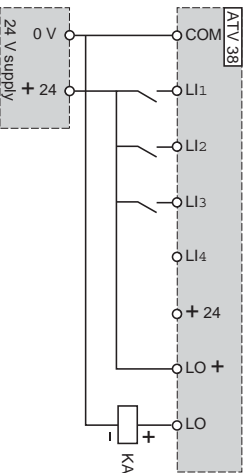

2-wire control

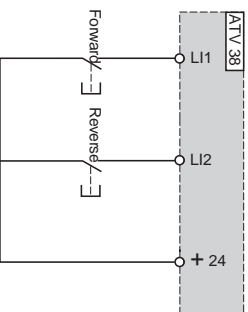

3-wire control

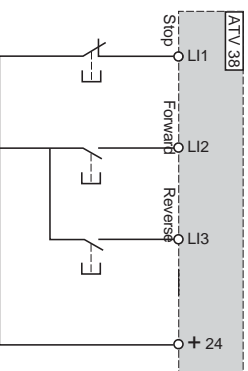

Motor protection via PTC probes, with optional analog input extension card

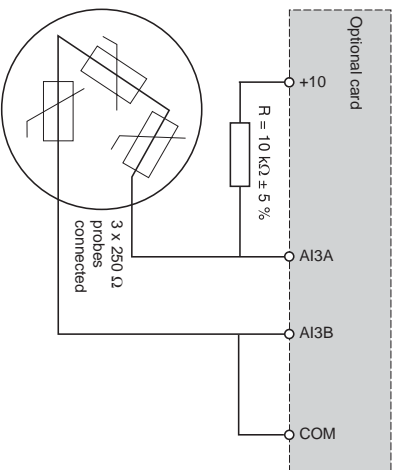

Additional radio interference suppression input filters

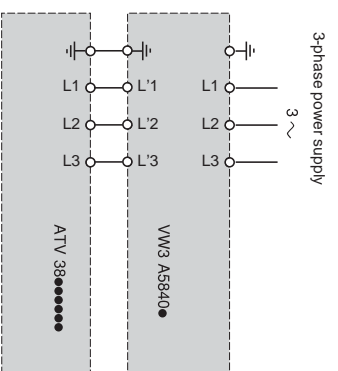

Output filters

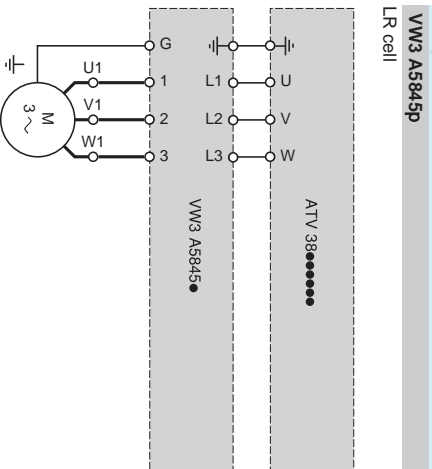

VW3 A6641p

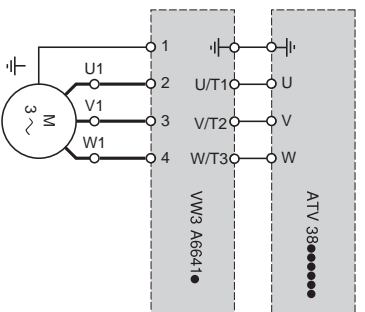

VW3 A6650p + VW3 A66421

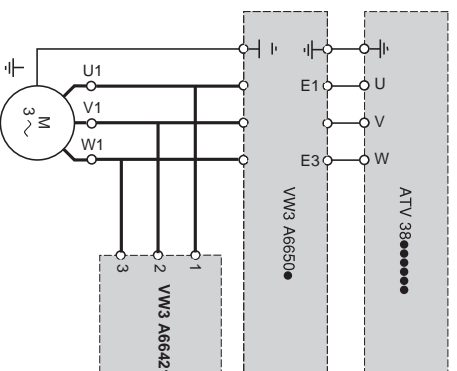

Principle

- b Grounds between drive, motor and cable shielding must have "high frequency," equipotentiality.
- b Use shielded cables with shielding connected to earth over 360° at both ends for the motor cable and the control-command cables. Conduit or metal ducting can be used for part of the shielding length provided that there is no break in continuity.
- b Ensure maximum separation between the power supply cable (mains supply) and the motor cable.

Installation diagram for ATV 38HU18N4 to HD79N4p drives

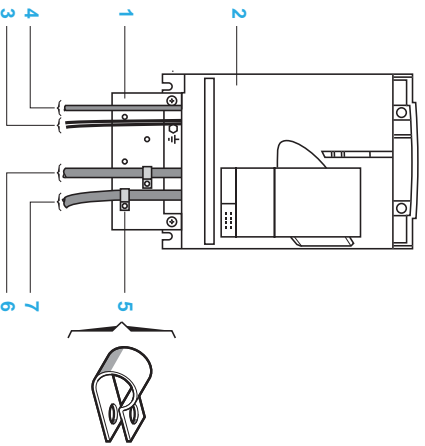

1 Steel plate supplied with the drive, to be fitted on it (machine ground)

2 Altivar 38

3 Non-shielded power supply wires or cable

4 Non-shielded wires for the output of the fault relay contacts

5 Fix and earth the shielding of cables 6 and 7 as close as possible to the drive:

- strip the shielding

- use the correct size clamps on the stripped part of the shielding to fix to metal sheet 1. The shielding must be clamped tightly enough on the metal sheet to

ensure good contact.

- types of clamp: stainless steel

6 Shielded cable (7) for connecting the motor.

7 Shielded cable (7) for connecting the control/command system For applications

requiring several conductors, use small cross-sections (0.5 mm²).

(1) The shielding of cables 6 and 7 must be connected to earth at both ends.

The shielding must be continuous and intermediate terminals must be in EMC shielded metal

boxes.

Nota :

- 1 Although there is an HF equipotential earth connection between the drive, the motor and the cable shielding, it is still necessary to connect the PE protective conductors (green-yellow) to the appropriate terminals on each of the devices.
- 2 If using an additional input filter, it should be mounted beneath the drive and connected directly to the mains supply via an unshielded cable. The connection 3 is then made via the filter cable.

Wiring recommendations for ATV 38HC10N4X to HC33N4X drives

Line chokes must be used if the prospective short-circuit line current is less than 22 kA. These chokes provide improved protection against overvoltages on the mains supply and reduce harmonic distortion of the current produced by the drive. The chokes are used to limit the line current.

Power wiring

The power wiring should consist of cables with 4 conductors or individual cables maintained as close as possible to the PE cable. Take care to route the motor cables well away from the power supply cables.

The power supply cables are not shielded. If a radio interference filter is used, the grounds for the filter and the drive should be at the same potential with low-impedance links at high frequency (fixed to unpainted steel plate with anti-corrosion treatment/machine ground wiring). The filter should be fitted as close as possible to the drive.

If the environment is sensitive to radiated radio interference, the motor cables should be shielded. On the drive side, fix and connect the shielding to the machine ground with rustproof clamps. The main function of the motor cable shielding is to limit their radio frequency radiation. Therefore, use 4-pole cables for the motor, connecting each end of the shielding in accordance with established practice for High Frequency wiring. The type of protective material (copper or steel) is less important than the quality of the connection at both ends. An alternative is to use a metal cable duct with good conductivity and no break in continuity.

Nota : When using a cable with a protective sleeve (NYCY type) which fulfils the dual function of PE + screen, it must be connected correctly to both the drive and the motor (its radiation efficiency is reduced).

Nota :

Control wiring

- 1 Shielding clamp
- 2 Cable grip. Check that the cable follows the path indicated by the clips.

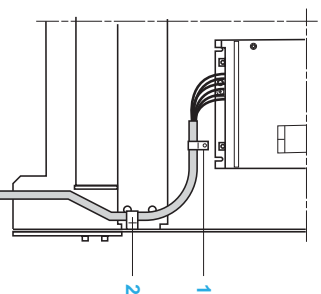

Variable speed drives for asynchronous motors

Altivar 38
Motor starters

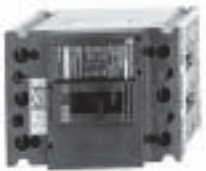

NS80HMA
+
LC1 D
+
ATV 38

Applications

Circuit-breaker/contactor/drive combinations can be used to ensure continuous service of the installation with optimum safety.

The selected circuit-breaker/contactor combination can reduce maintenance costs in the event of a short-circuit by minimising the time required to make the necessary repairs and the cost of replacement equipment. The combinations suggested correspond to Type 2 coordination.

Type 2 coordination: A short-circuit will not damage the device or affect its settings. The motor starter should be able to operate once the electrical fault has been removed. The electrical isolation provided by the circuit-breaker will not be affected by the short-circuit. Welding of the contactor contacts is permissible if they can be separated easily.

The downstream contactor is not affected by type 2 coordination.

The drive controls the motor, provides protection against short-circuits between the drive and the motor and protects the motor cable against overloads. This overload protection is provided by the driver's motor thermal protection.

If this protection is removed, external thermal protection should be provided. Before restarting the installation, the cause of the trip must be removed.

3-phase supply voltage: 380 to 415 V (for 0.75 to 315 kW motors)

Motor circuit-breaker: NSppppMA: product sold under the Merlin Gerin brand

Composition of contactors:

LC1-D09 to LC1-D115: 3 poles + 1 "N/O" auxiliary contact and 1 "N/C" auxiliary contact
LC1-Fpp to LC1-D115: 3 poles + 1 "N/O" auxiliary contact and 1 "N/C" auxiliary contact

Motor (1)	Circuit-breaker (1)	Line contactor (3)	Downstream contactor Reference (4)	Variable speed drive Reference (5)
Power kW	Reference (2)	Rating A	Reference	Reference
0.75	GV2 L08	4	LC1 D18pp	LC1 D09BL ATV 38HU18N4
1.5	GV2 L10	6.3	LC1 D18pp	LC1 D09BL ATV 38HU29N4
2.2	GV2 L14	10	LC1 D18pp	LC1 D09BL ATV 38HU41N4
3	GV2 L16	14	LC1 D18pp	LC1 D09BL ATV 38HU54N4
4	GV2 L16	14	LC1 D18pp	LC1 D09BL ATV 38HU72N4
5.5	GV2 L22	25	LC1 D25pp	LC1 D09BL ATV 38HU90N4
7.5	NS80HMA50	50	LC1 D40pp	LC1 D09BL ATV 38HD12N4
11	NS80HMA50	50	LC1 D40pp	LC1 D25BL ATV 38HD16N4
15	NS80HMA50	50	LC1 D40pp	LC1 D25BL ATV 38HD23N4
18.5	NS80HMA50	50	LC1 D40pp	LC1 D25pp ATV 38HD25N4p
22	NS80HMA50	50	LC1 D50pp	LC1 D32pp ATV 38HD28N4p
30	NS80HMA80	80	LC1 D65pp	LC1 D40pp ATV 38HD33N4p
37	NS80HMA80	80	LC1 D80pp	LC1 D50pp ATV 38HD46N4p
45	NS100HMA100	100	LC1 D80pp	LC1 D80pp ATV 38HD54N4p
55	NS160HMA150	150	LC1 D115pp	LC1 D80pp ATV 38HD64N4p
75	NS160HMA150	150	LC1 D150pp	LC1 D115pp ATV 38HD79N4p
90	NS250pMA	220	LC1 F185pp	LC1 D115pp ATV 38HC10N4X
110	NS250pMA	220	LC1 F225pp	LC1 D115pp ATV 38HC13N4X
132	NS250pMA	220	LC1 F265pp	LC1 D1505pp ATV 38HC15N4X
160	NS400pMA	320	LC1 F330pp	LC1 F225pp ATV 38HC19N4X
200	NS400pMA	320	LC1 F400pp	LC1 F265pp ATV 38HC23N4X
220	NS630pMA	500	LC1 F400pp	LC1 F330pp ATV 38HC25N4X
250	NS630pMA	500	LC1 F500pp	LC1 F400pp ATV 38HC28N4X
280	NS630pMA	500	LC1 F630pp	LC1 F400pp ATV 38HC31N4X
315	NS630pMA	500	LC1 F630pp	LC1 F500pp ATV 38HC33N4X

(1) Standard power ratings for 4-pole, 50/60 Hz, 400 V motors

(2) Replace p with N, H or L, according to the breaking capacity, in the table below.

Breaking capacity of circuit-breakers according to standard IEC60947-2

380/415 V	Icu (kA)
GV2 L	50
NS80HMA	70
NS80HMA	70
NS100pMA	25
NS100pMA	70
NS160pMA, NS250pMA	35
NS160pMA, NS250pMA	70
NS400pMA, NS630pMA	-
NS400pMA, NS630pMA	70

(3) Replace pp with the control circuit voltage reference indicated in the table on the opposite page.

(4) LC1-DppBL contactors have 2.4 V d.c. low consumption coils (100 mA). Up to 15 kW, they are powered by an internal drive power supply. For power ratings above this level, use an external supply and complete the contactor coil voltage as shown in the table (3).

(5) For drives without integrated EMC filter, replace the p with an X.

Note : The maximum line current is determined with a maximum upstream short-circuit power rating of 5 kA at between 0.75 and 5.5 kW (22 kA between 7.5 and 315 kW).

Variable speed drives for asynchronous motors

Altivar 38
Motor starters

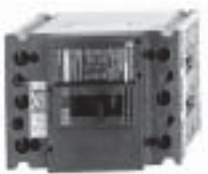

NS80HMA
+
LC1 D
+
ATV 38

3-phase supply voltage: 440 to 460 V (for 0.75 to 315 kW motors)

Motor circuit-breaker

NSpppMMA: product sold under the Merlin Gerin brand

Composition of contactors

LC1-D09 to LC1-D115: 3 poles + 1 "N/O" auxiliary contact and 1 "N/C" auxiliary contact
LC1-Fpp to LC1-D115: 3 poles + 1 "N/O" auxiliary contact and 1 "N/C" auxiliary contact

Power kW	Reference	Rating A	Line contactor		Downstream contactor		Variable speed drive Reference
			Reference	Reference	Reference	Reference	
0.75	GV2 L08	4	LC1 D1810pp	LC1 D09BL	LC1 D09BL	ATV 38HU18N4	
1.5	GV2 L10	6.3	LC1 D2510pp	LC1 D09BL	LC1 D09BL	ATV 38HU29N4	
2.2	GV2 L10	6.3	LC1 D2510pp	LC1 D09BL	LC1 D09BL	ATV 38HU41N4	
3	GV2 L14	10	LC1 D2510pp	LC1 D09BL	LC1 D09BL	ATV 38HU54N4	
4	GV2 L14	10	LC1 D2510pp	LC1 D09BL	LC1 D09BL	ATV 38HU72N4	
5.5	NS80HMA50	50	LC1 D4011pp	LC1 D09BL	LC1 D09BL	ATV 38HU90N4	
7.5	NS80HMA50	50	LC1 D4011pp	LC1 D09BL	LC1 D09BL	ATV 38HD12N4	
11	NS80HMA50	50	LC1 D4011pp	LC1 D25BL	LC1 D25BL	ATV 38HD16N4	
15	NS80HMA50	50	LC1 D4011pp	LC1 D25BL	LC1 D25BL	ATV 38HD23N4	
18.5	NS100LMA50	50	LC1 D8011pp	LC1 D2510pp	LC1 D2510pp	ATV 38HD25N4p	
22	NS100LMA50	50	LC1 D8011pp	LC1 D3210pp	LC1 D3210pp	ATV 38HD28N4p	
30	NS100LMA50	50	LC1 D8011pp	LC1 D4011pp	LC1 D4011pp	ATV 38HD33N4p	
37	NS100LMA80	100	LC1 D8011pp	LC1 D5011pp	LC1 D5011pp	ATV 38HD46N4p	
45	NS100LMA100	100	LC1 D8011pp	LC1 D8011pp	LC1 D8011pp	ATV 38HD54N4p	
55	NS100LMA100	100	LC1 D115pp	LC1 D8011pp	LC1 D8011pp	ATV 38HD64N4p	
75	NS160HMA150	150	LC1 D115pp	LC1 D150pp	LC1 D150pp	ATV 38HD79N4p	
90	NS160pMA	150	LC1 D115pp	LC1 D150pp	LC1 D150pp	ATV 38HC10N4X	
110	NS250pMA	220	LC1 F185pp	LC1 D115pp	LC1 D115pp	ATV 38HC13N4X	
132	NS250pMA	220	LC1 F185pp	LC1 F265pp	LC1 F265pp	ATV 38HC15N4X	
160	NS400pMA	320	LC1 F265pp	LC1 F225pp	LC1 F225pp	ATV 38HC19N4X	
200	NS400pMA	320	LC1 F330pp	LC1 F265pp	LC1 F265pp	ATV 38HC23N4X	
220	NS400pMA	320	LC1 F400pp	LC1 F330pp	LC1 F330pp	ATV 38HC28N4X	
250	NS630pMA	500	LC1 F400pp	LC1 F400pp	LC1 F400pp	ATV 38HC28N4X	
280	NS630pMA	500	LC1 F500pp	LC1 F400pp	LC1 F400pp	ATV 38HC31N4X	
315	NS630pMA	500	LC1 F500pp	LC1 F500pp	LC1 F500pp	ATV 38HC33N4X	

(1) Standard power ratings for 4-pole motors 50/60 Hz 400 V

(2) Replace p with N, H or L, according to the breaking capacity, in the table below.

Breaking capacity of circuit-breakers according to standard IEC60947-2

400/460 V lcu (kA)

GV2 L08, L10	> 100
GV2 L14, L16, L22	20
NS80HMA	65
440/460 V	
NS100pMA	N
NS160pMA, NS250pMA	25
NS400pMA, NS630pMA	35
	65
	65
	130

(3) Replace pp with the control circuit voltage reference indicated in the table below.

a.c. control circuit	Reference
Volts AC	
50/60 Hz	B7 E7 F7 FET M7 P7 U7 V7

(4) LC1-DppBL contactors have 24 V d.c. low consumption coils (100 mA). Up to 15 kW, they are powered by an internal drive power supply. For power ratings above this level, use an external supply and complete the contactor coil voltage as shown in the table (3).

Nota : The maximum line current is determined with a maximum upstream short-circuit power rating of 5.5 kA at between 0.75 and 5.5 kW (22 kA between 7.5 and 31.5 kW).

Variable speed drives for asynchronous motors Altivar 38

Summary of functions

Operating speed range	page 33
Acceleration and deceleration ramp times	page 33
Acceleration and deceleration ramp profiles	page 33
Alternate ramp switching	page 34
Automatic adaptation of deceleration ramp	page 34
Reverse operation	page 34
Disabling reverse	page 34
Jog operation	page 34
2-wire control	page 35
3-wire control	page 35
+/- speed	page 35
Save reference	page 35
Motor switching	page 36
Downstream contactor control	page 36
Preset speeds	page 36
Adjusting analog input AI2	page 36
Summing inputs	page 37
Reference switching	page 37
PI regulator	page 37
Speed feedback with tachogenerator	page 38
Incremental speed feedback	page 38
Incremental speed reference	page 38
Controlled stop	page 38
Automatic catching a spinning load with speed detection	page 39
Automatic restart	page 39
Maintaining the speed following loss of the 4-20 mA reference	page 39
Operating speed limit at low speed	page 39
Fault reset	page 39
General reset (inhibits all faults)	page 39
Forced local mode	page 39
External fault	page 39
Fault relay, unlocking	page 40
Motor thermal protection	page 40
PTC probe protection	page 40
Drive thermal protection	page 40
Switching frequency, noise reduction	page 40
Energy saving	page 41
Adaptation of the current limit	page 41
Auto-tuning	page 41
Skip frequencies	page 41
Reassignable logic outputs	page 41
Analog outputs AO1 and AO	page 41
Adjusting analog outputs AO1 and AO	page 41
Configurable I/O	page 42

Drive factory setting

To facilitate installation of the drive, the functions, parameters and I/O have been assigned to meet the requirements of pumping and ventilation applications.

Drive I/O

- Logic input LI1: forward
- Logic input LI2: reverse
- Logic input LI3: fault reset
- Logic input LI4: not assigned
- Analog input AI1: speed reference
- Analog input AI2: summing speed reference
- Relay R1: drive fault
- Relay R2: drive running
- Analog output AO1: motor frequency

Extension card I/O

- Logic input LI5: ramp switching
- Logic input LI6: not assigned
- Analog input AI3 or encoder inputs: summing speed reference
- Logic output LO: high speed reached
- Analog output AO: motor current

Variable speed drives for asynchronous motors Altivar 38

b Operating speed range
Used to determine 2 frequency limits which define the speed range permitted by the machine under actual operating conditions. Three operating modes are possible:

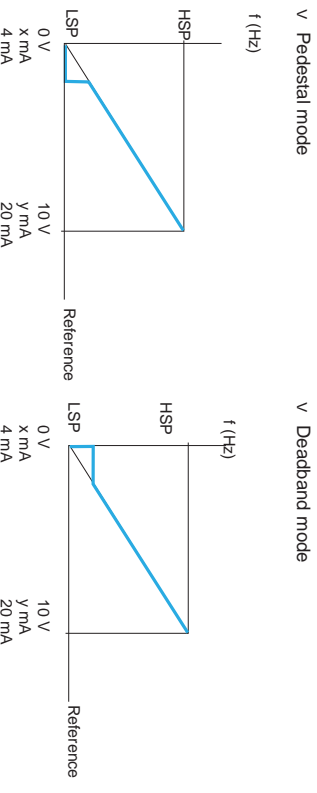
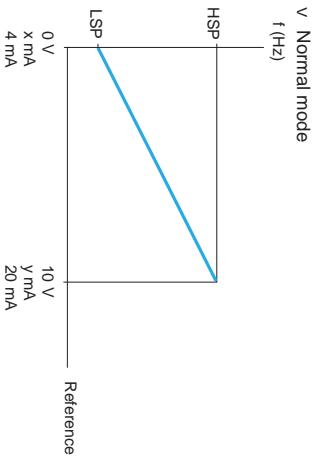

LSP: low speed, from 0 to HSP, factory setting 0
HSP: high speed, from LSP to f max., factory setting 50/60 Hz
x: configurable between 0 and 20 mA, factory setting 4 mA
y: configurable between 0 and 20 mA, factory setting 20 mA

b Acceleration and deceleration ramp times
Used to define acceleration and deceleration ramp times according to the application and the machine dynamics.

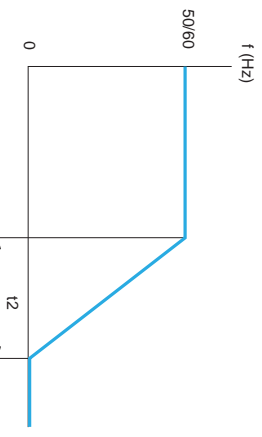
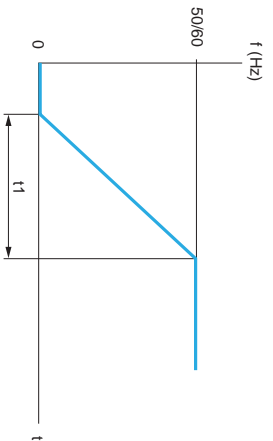

Adjustment for t1 and t2 between 0.05 and 999.9 s, factory setting 3 s.

v S-shape ramps

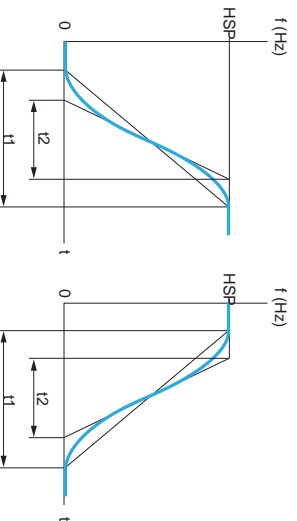

HSP: high speed
The curve coefficient is fixed, with $t2 = 0.6 \times t1$, where t1 = set ramp time

v U-shape ramps

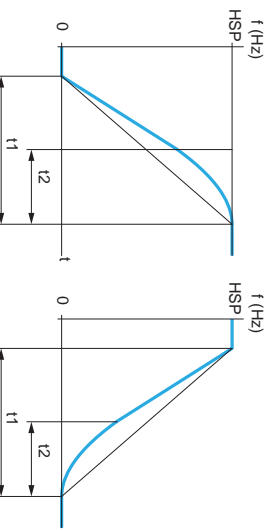

HSP: high speed
The curve coefficient is fixed, with $t2 = 0.5 \times t1$, where t1 = set ramp time

Variable speed drives for asynchronous motors Altivar 38

b Alternate ramp switching

Used to switch 2 acceleration or deceleration ramp times, which can be adjusted separately. The function is enabled by reassigning 1 logic input or by defining 1 frequency threshold. It is suitable for machines with fast continuous speed correction and high speed lathes with acceleration and deceleration limiting above certain speeds.

b Automatic adaptation of deceleration ramp

Used to automatically adapt the deceleration ramp if the initial setting is too low when the load inertia is taken into account. This function avoids the drive locking in the event of an **excessive braking** fault.

b Reverse operation

Used to reverse the direction of operation by means of a logic input. LI2 is assigned to this function in the factory setting. This function can be suppressed in non-reversing motor applications by reassigning input LI2 to a different function.

b Disabling reverse direction

Used to:
 v Inhibit operation in the opposite direction to that controlled by the logic inputs, even if this reversal is required by a summing or feedback control function.
 v Inhibit reverse operation if it is requested using the REV key on the terminal.
 To be used if the direction of operation should not be reversed (example: fan).

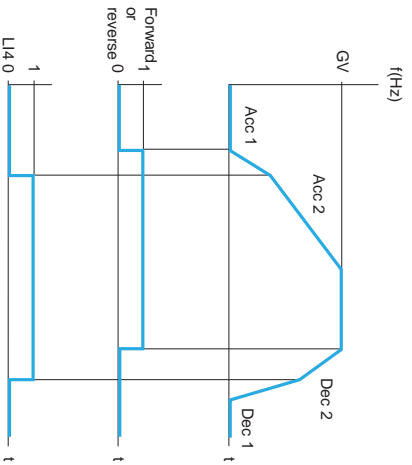

Acceleration 1 (Acc 1) and deceleration 1 (Dec 1):
 - adjustment 0.05 to 999.9 s
 - factory setting 3 s

Acceleration 2 (Acc 2) and deceleration 2 (Dec 2):
 - adjustment 0.05 to 999.9 s,
 - factory setting 5 s.

HSP: high speed

Acceleration and deceleration
 Example of switching using logic input LI4

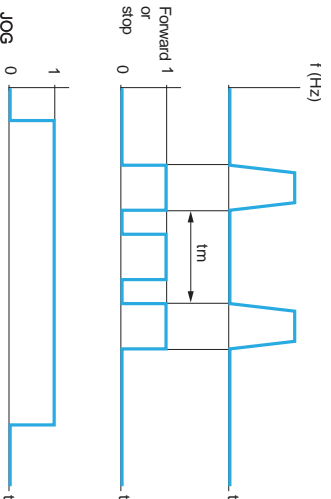

Speed reference:
 - adjustment 0 to 10 Hz
 - factory setting 10 Hz

Minimum time t_m between
 2 pulses:
 - adjustment 0 to 2 s
 - factory setting 0.5 s

Jog function

b Jog operation
 Used for pulse operation at minimum ramp times (0..1 s), limited speed reference and minimum time between 2 pulses.
 Enabled by means of an adjustable logic input LI, assigned to this function, and pulses given by the operating direction command.
 This function is suitable for machines with product insertion in manual mode (example: gradual movement of the mechanism during maintenance operations).

Variable speed drives for asynchronous motors

Altivar 38

b 2-wire control

Used to control the direction of operation by means of a maintained contact. Enabled by means of 1 or 2 logic inputs (one or two directions). This function is suitable for all one or two direction applications. 3 operating modes are possible:

- v detection of the state of the logic inputs,
- v detection of a change in state of the logic inputs,
- v detection of the state of the logic inputs with forward operation always having priority over reverse.

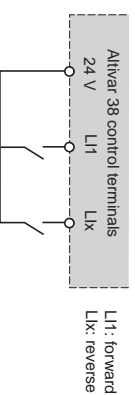

Wiring diagram for 2-wire control

b 3-wire control

Used to control the operating and stopping direction by means of pulsed contacts. Enabled by means of 2 or 3 logic inputs (non-reversing or reversing). This function is suitable for all non-reversing and reversing applications.

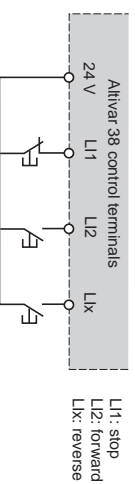

Wiring diagram for 3-wire control

b +/- speed

Used to increase or decrease a speed reference by means of 1 or 2 logic commands, with or without the last reference being saved (motorised potentiometer function). The maximum speed is given by the reference applied to the analog inputs. For example, connect AI1 to the +10V. Enabled by assigning 1 or 2 logic inputs. This function is suitable for centralised control of a machine with several sections operating in one direction or for controlling pendant control station, using a handling crane in two operating directions.

v Without saving of the last reference and a single logic input ("± speed")

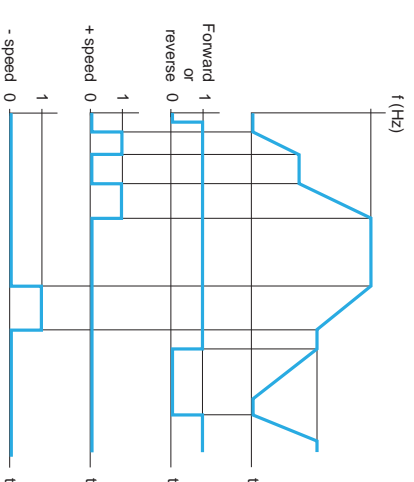

v With saving of the last reference and 2 logic inputs

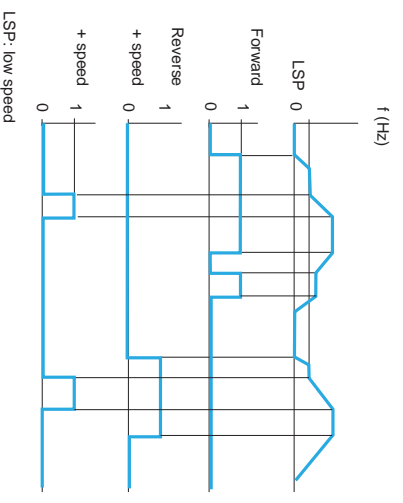
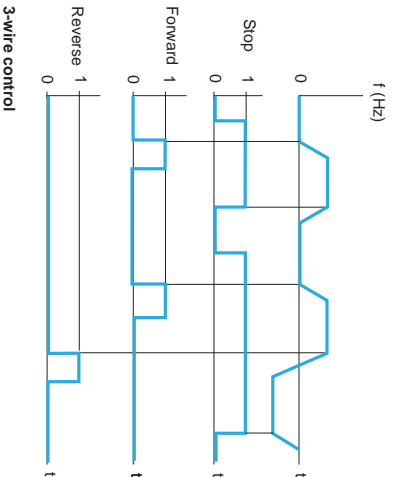

LSP: low speed

Example with double action buttons

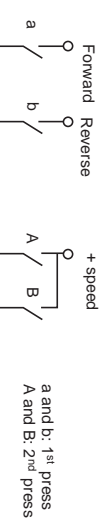

Nota : This type of "+/- speed" control is incompatible with 3-wire control.

b Save reference

This function is associated with "+/- speed" control. Select yes or no. Enables the new speed reference to be applied if the run command or line supply is lost. The save is applied the next time a run command is received.

Variable speed drives for asynchronous motors Altivar 38

b Motor switching

Allows two motors with different powers to be supplied successively by the same drive. Switching must take place with the drive stopped and locked, using an appropriate sequence at the drive output.

The function can be used to adapt the motor parameters. The following parameters are switched automatically:

- ✓ nominal motor current,
 - ✓ injection current.
- Motor thermal protection is disabled by this function. Enabled by assigning logic input LI to this function. The associated parameter is the coefficient which provides the ratio between the power of the smallest motor and the power of the drive: 0.2 to 1.

b Downstream contactor control

Allows the drive to control a contactor located between the drive and the motor.

The request to close the contactor is made when a run command appears.

The request to open the contactor is made when there is neither a run command nor a current present in the motor (freewheel stop, drive locked or braking terminated).

Enabled by means of logic output LO or relay R2.

✓ This function avoids the need for frequency switching on the power circuit upstream of the drive (otherwise premature aging of the filtering capacitors will occur) and requires a specific connection diagram (see page 27).

✓ **This function must be used for cycles < 60 s with motor isolation on stopping.**

b Preset speeds

Used to switch preset speed references.

2, 4, or 8 preset speeds can be selected.

Enabled by means of 1, 2 or 3 logic inputs.

The preset speeds can be adjusted in increments of 0.1 Hz to 0 Hz up to the maximum speed.

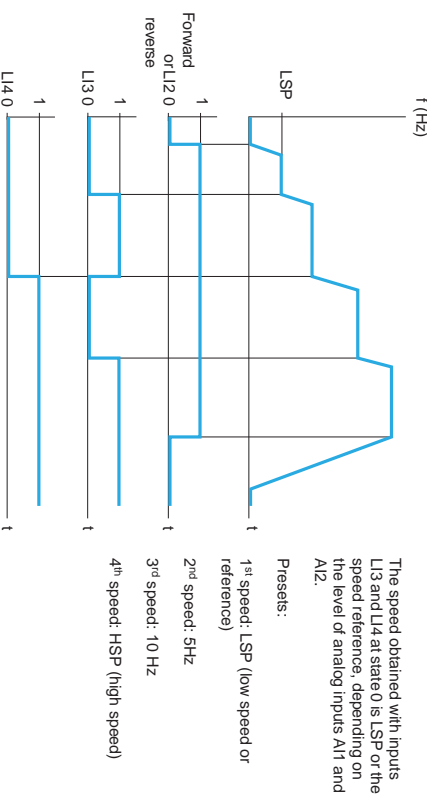

Example of operation with 4 preset speeds

b Adjusting analog input AI2

It is possible to modify the characteristics of analog current input AI2.

Factory setting: 4 -20 mA.

Other values: 0-20 mA, 20-4 mA or X-Y mA by programming X and Y with a precision of 0.1 mA.

Variable speed drives for asynchronous motors

Altivar 38

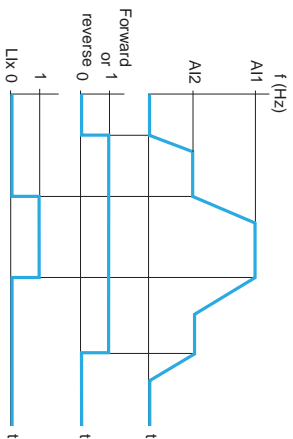

Example of reference switching

b Summing inputs
 Analog input AI2 (and/or analog input AI3 with extension card) can be assigned as a summing input with AI1.
 The sum is limited to the value corresponding to the high speed (HSP).
 This function is suitable for machines on which the speed is controlled by a process controller signal on input AI2.

b Reference switching

Allows 2 analog references to be switched by means of a logic command. This function avoids having to switch low level signals and makes the 2 reference inputs AI1 and AI2 independent. Enabled by means of 1 reassignable logic input LI.
 This function is suitable for all machines with automatic/manual operation.
 Automatic control via a sensor on input AI2, enabled by setting the logic input to 0.
 Manual control by means of potentiometer on input AI1 (local control).

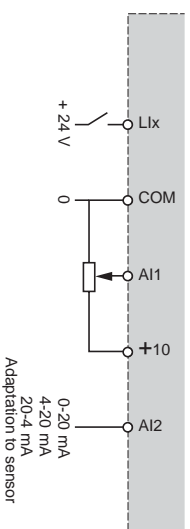

Connection diagram for reference switching

b PI regulator

Used for simple control of a flow rate or a pressure with a sensor which supplies a feedback signal adapted to the drive.
 This function is suitable for pumping and ventilation applications.

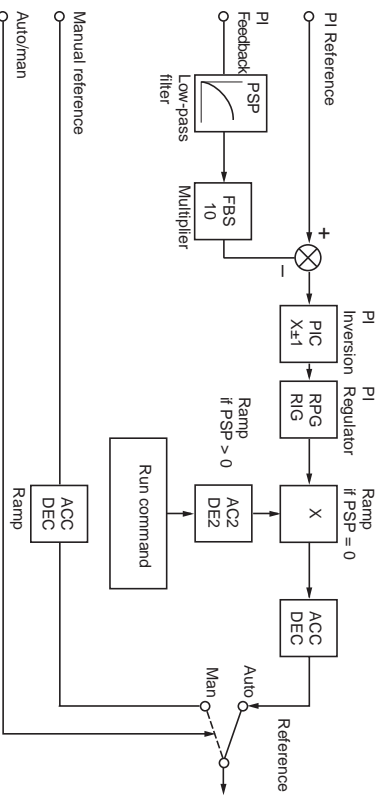

ACC: Acceleration regulator
ACC2: Acceleration 2
DEC: Deceleration
DE2: Deceleration 2
FBS: PI feedback multiplication coefficient
PIC: Reversal of the direction of correction of the PI regulator
PSP: Filter time constant setting on the PI feedback
RIG: PI regulator integral gain
RPg: PI regulator proportional gain

Preset PI references:
 2 or 4 preset references require the use of 1 or 2 logic inputs respectively.
 2 preset references

Assign: Lix to Pr2

Lix	Reference	Liy	Lix	Reference
0	Analog reference 0 (= 10 V)	0	0	Analog reference PI2 (adjustable)
1	Process max	0	1	PI3 (adjustable) Process max (= 10 V)
1	Process max	1	0	PI2 (adjustable) Process max (= 10 V)

Variable speed drives for asynchronous motors

Altivar 38

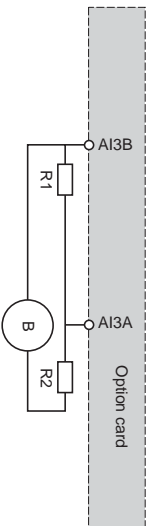

Connection diagram for speed feedback via tachogenerator

b Speed feedback with tachogenerator

Used for precise speed control, irrespective of the state of the motor load.

Assigned to logic input AI3, with extension card/analog input

The maximum tachogenerator voltage must be between 5 and 9 V. If necessary, use an external divider bridge to adapt this value (1).

The value can be set precisely in the "Adjust" menu. Consistency between the motor frequency and the speed feedback is monitored in the drive fault management system.

This function is suitable for all applications requiring exact speed irrespective of the load.

(1) Example: Motor 1500 rpm at 50 Hz, tachogenerator 0.06 V/rpm, max. speed set to 75 Hz (speed 2250 rpm),

maximum voltage $0.06 \times 2250 = 135 \text{ V}$,

recommended tachogenerator current 10 mA, therefore $R1 + R2 = 135/10 = 13.5 \text{ k}\Omega$,

average voltage on the input = 7 V, therefore $R1 = 7/10 = 0.7 \text{ k}\Omega$ or 680 Ω , nearest standard

value, $R2 = 13.5 - R1$, or 12 k Ω , nearest standard value,

exact voltage on AI3 = $135 \times R1/(R1 + R2) = 135 \times 0.68/12.68 = 7.24 \text{ V}$.

Use appropriate power resistors (min. 2 W).

The speed feedback should be scaled exactly by programming (when the device is set up).

b Incremental speed feedback

Used for precise speed control, irrespective of the state of the motor load.

Assigned to logic inputs A, A-, B, B- on the extension card/encoder inputs.

NPN type open collector output, nominal voltage 24 V C

Max. read frequency 33 kHz at max. speed HSP

v Use in 1 or 2 operating directions

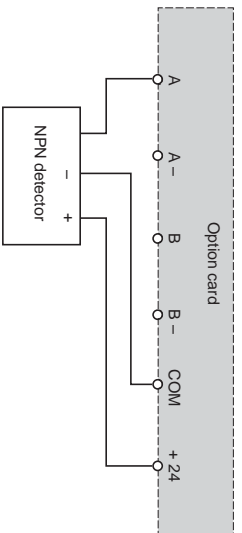

Connection diagram with inductive sensor or simple control photoelectric sensor (not very precise at low speeds)

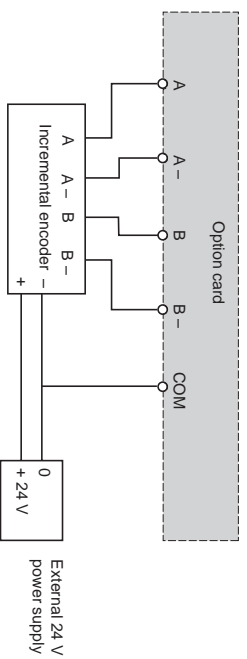

Connection diagram with incremental encoder for precise control at low speeds

Consistency between the motor frequency and the speed feedback is monitored in the drive fault management system.

This function is suitable for applications requiring precise speed control irrespective of the load and a high level of immunity to interference.

b Incremental speed reference

Enabled by assigning the logic inputs on the above extension card/encoder inputs to the "summing inputs" function.

Synchronization of the speed of a number of drives.

Nominal voltage 24 V C

Max. reading frequency 33 kHz at max. speed HSP

b Controlled stop

Used to define stop modes in addition to the standard drive stops. These stop requests always have priority.

Three stop modes are available for selection:

v Freewheel stop: the drive is locked and the motor stops in accordance with the inertia and the resistive torque,

v fast stop: the motor brakes to a stop with the deceleration ramp time divided by a coefficient which can be set between 1 and 10,

v d.c. injection braking: adjustment of the time (0 to 30 s, factory setting 0.5 s) and current (10% to 110% of the nominal drive current in high torque applications, factory setting 70%). Continuous braking is possible but is limited automatically to another adjustable value (10% to 100% of the nominal motor current, factory setting 50%) after 30 s.

Enable modes:

v By means of 1 reassignable logic input LI: active at 0 for freewheel stop and fast stop, active

at 1 for injection stop,

v automatically when stopping (frequency less than 0.1 Hz) for injection braking, as this function can be combined with the others. In this case, only the current after 30 s of injection can be adjusted.

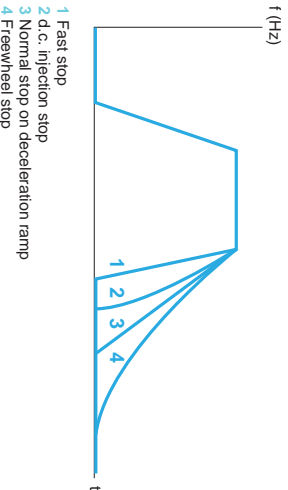

Examples of controlled stops

Variable speed drives for asynchronous motors Altivar 38

b Automatic catching a spinning load with speed detection ("catch on the fly")

- Used to restart the motor smoothly after one of the following events:
 - v loss of line supply or power off,
 - v fault reset or automatic restart,
 - v freewheel stop or injection stop with logic input,
 - v uncontrolled loss of power downstream of the drive.

On restarting, the effective speed of the motor is detected in order to restart on the ramp at this speed and return to the reference speed. The speed detection time can be up to 1 s depending on the initial deviation.

Factory setting: active.

This function is automatically disabled if the brake sequence is configured.

This function is suitable for machines for which the loss of motor speed is negligible during the supply loss time (machines with high inertia), fans and pumps driven by a residual flux, etc.

b Automatic restart

Enables the drive to be restarted automatically after locking following a fault if this fault has disappeared and if the other operating conditions permit a restart.

This restart is performed by a series of automatic attempts at 30 s intervals.

If a restart has not been possible after 6 attempts, the procedure is abandoned and it remains locked until it has been switched off and on again.

Factory setting: inactive.

The faults permitting this restart are:

- v supply overvoltage,
- v motor thermal overload,
- v drive thermal overload,
- v loss of 4-20 mA reference,
- v d.c. bus overvoltage,
- v external fault,
- v motor phase loss,
- v serial link fault,
- v mains voltage too low. For this fault, the function is always active, even if it is not configured. For this type of fault, the drive fault relay remains activated if the function is configured. The speed reference and the direction of operation must be maintained for this function. This function is suitable for machines or installations in continuous operation or without monitoring, and where a restart will not endanger equipment or personnel in any way.

b Maintaining the speed following loss of the 4-20 mA reference

Enables the motor speed to be maintained following loss of the 4-20 mA reference.

This function is suitable for applications which must not be interrupted.

b Limiting low speed operating time (LSP)

The motor is stopped automatically after an operating period at low speed (LSP) with zero reference and run command present.

This time can be set between 0.1 and 999.9 s or no limit. Factory setting 5 s. The motor restarts automatically on the ramp when the reference reappears or if the run command is broken and then re-established.

This function is suitable for automatic stopping/starting on pressure-regulated pumps.

b Fault reset

Enables faults to be reset by means of a logic input LI which can be reassigned to this function. The restart conditions after a reset to zero are the same as those of a normal power-up.

Fault reset: overvoltage, overspeed, external fault, drive overheating, loss of motor phase, d.c. bus overvoltage, loss of 4-20 mA reference, load veering, motor overload if the thermal state is less than 100%, serial link fault.

"Mains undervoltage" and "mains phase loss" faults are reset automatically when the mains supply is restored.

This function is suitable for applications with drives which are difficult to access.

b General reset (inhibits all faults)

This function can be used to inhibit all faults, including thermal protection (forced operation) except short-circuit faults, to ensure operation unless irreparable damage has been caused in extreme operating conditions.

This function is suitable for applications where a restart could be vital (tunnel smoke extraction system).

b Forced local mode

Forced local mode switches the drive from serial link control to terminal control. A logic input LI can be reassigned to this function.

b External fault

When the input assigned to this function changes to 1, the motor stops in accordance with the parameter configuration and the drive locks in an "EPF external fault" fault.

Variable speed drives for asynchronous motors Altivar 38

b Fault relay, unlocking

The fault relay is energised when the drive is powered up and is not faulty. It has one "C/O" contact at the common point.

The drive can be unlocked after a fault in one of the following ways:

- v By switching the drive off until the "power on" LED goes out and then switching it on again,
- v by assigning a logic input to the "fault reset" function,
- v using the "automatic restart" function (if it has been configured).

b Motor thermal protection

Indirect motor thermal protection is implemented via continuous calculation of its theoretical temperature rise.

The drive is locked by default if this temperature rise exceeds 118% of the nominal temperature rise.

v This function is suitable for applications with self-cooled or force-cooled motors:

The microprocessor calculates the theoretical temperature rise of the motor based on various elements:

- the operating frequency,
- the current taken by the motor,
- the operating time,
- the maximum ambient temperature around the motor (40°C).

Adjustment:

0.25 to 1.36 times the nominal current of the drive in high torque applications; factory setting 0.9 times the nominal current indicated on the motor rating plate.

v Special applications:

Adaptation of thermal protection in the fault configuration menu:

- applications with force-cooled motor: in this case, the tripping curves are those shown opposite for the nominal frequency 50/60 Hz,
- suppression of thermal protection in harsh environments: temperature greater than 40°C around the motor, which may cause the cooling fins to become clogged (provide direct thermal protection via thermistor probes integrated into the motor),
- motor thermal protection using PTC probes: see "thermal protection with PTC probes" function with option card.
- if several motors are connected in parallel on the same drive, fit each motor starter with a thermal relay to reduce the risk of the load being distributed unevenly.

Nota : When the drive is switched off, calculation I^2t is saved and the amount by which it has decreased is calculated.

b PTC probe protection

Used for motor thermal protection (if the motor is fitted with PTC probes).

Assigned to logic input AI3, with extension card/analog input.

Maximum resistance of probe circuit at 20°C: 750 Ω (3 x 250 Ω probes connected in series).

Probe break and short-circuit faults are monitored.

This function is suitable for use in all applications.

b Thermal protection of drive

Enables the drive to be protected directly via a thermistor fitted on the heatsink, ensuring that components are protected in the event of poor ventilation or excessive ambient temperatures. Locks the drive in the event of a fault.

b Switching frequency, noise reduction

High frequency switching of the intermediate d.c. voltage can be used to supply the motor with a current wave with low harmonic distortion.

The switching frequency can be adjusted to reduce the noise generated by the motor.

In addition, the switching frequency is random in order to avoid resonance. This function can be disabled if it causes instability.

This function is suitable for all applications which require low motor noise.

v Without derating, for continuous or intermittent operation (frequencies of 0.5 and 1 KHz should be used for long cable lengths).

Drive	Configurable switching frequency - KHz
ATV 38HU18N4 to HD46N4	0.5-1-2-4
ATV 38HD25N4X to HD46N4X	
ATV 38HU54N4 to HC33N4	0.5-1-2
ATV 38HD54N4X to HC33N4X	

v Without derating, with intermittent operating cycle or with derating by one power rating in continuous operation (1).

Drives	Configurable switching frequency - KHz
ATV 38HU18N4 to HD23N4	8-12-16
ATV 38HU25N4 to HD46N4	8-12
ATV 38HU25N4X to HD46N4X	
ATV 38HU54N4 to HD79N4	4-8
ATV 38HU54N4X to HD79N4X	
ATV 38HC10N4X to HC33N4X 4	

(1) In intermittent operation, the frequency automatically decreases in the case of overheating.

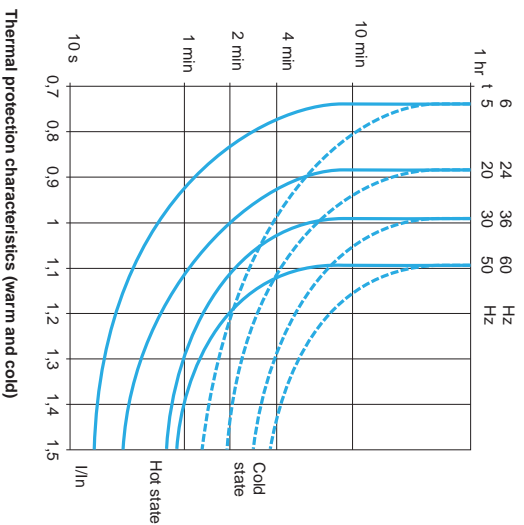

Thermal protection characteristics (warm and cold)

Variable speed drives for asynchronous motors Altivar 38

b Energy saving
Enables the power consumption to be adapted according to the load, improving efficiency.

b Adaptation of the current limit
The current limit can be adapted automatically according to the speed in order to avoid a motor overload fault.
This function is suitable for ventilation applications in which the load curve changes according to the air density.

b Auto-tuning
Auto-tuning is only possible by means of user intervention using the dialogue tools and an assignable logic input. It is used to optimize performance.
This function is suitable for use in all applications.

b Skip frequencies
Skip frequencies can be used to suppress up to three critical speeds which may be the cause of mechanical resonance.
Prolonged operation of the motor can be prohibited on one to three adjustable frequency bands (with a band width of 5 Hz), which can be set within the operating range.
This function is suitable for use in fans and centrifugal pumps.

b Reassignable logic outputs
Relay R2 (or LO solid state output with I/O extension card):

- v Remote signalling of the following information as required:
 - drive operating (running or braking),
 - frequency threshold reached (greater than or equal to an adjustable threshold),
 - 2nd frequency threshold reached,
 - frequency reference reached (motor frequency equal to the reference),
 - current threshold reached (greater than or equal to an adjustable threshold),
 - motor thermal threshold reached (greater than or equal to an adjustable threshold),
 - drive thermal threshold reached (greater than or equal to an adjustable threshold),
 - high speed reached,
 - loss of 4-20 mA reference.
- v Remote downstream contactor control

b Analog outputs AO1 (or AO with I/O extension card)
Analog outputs AO and AO1 (x-y mA) can be assigned to the following parameters:

- motor current (y mA = twice the nominal current of the drive),
- motor frequency (y mA = maximum frequency),
- ramp output (y mA = maximum frequency),
- signed ramp (x mA = maximum reversing frequency, y mA = maximum forward frequency),
- PI reference (x mA = minimum reference, y mA = maximum reference),
- PI feedback (x mA = minimum feedback, y mA = maximum feedback),
- PI error (x mA = maximum error < 0, y mA = minimum error > 0),
- PI integral (y mA = integral saturated),
- motor power (x mA = 0% of the nominal motor power, y mA = 200% of the nominal motor power),
- motor thermal state calculated: (x mA = 0%, y mA = 200%),
- drive thermal state: (x mA = 0%, y mA = 200%).

Nota : x and y can be set between 0 and 20 mA

b Adjusting the analog outputs AO1 (or AO with I/O extension card)
The characteristics of analog current outputs AO and AO1 can be modified.

Factory setting: 0 -20 mA
Other values: 4-20 mA, 20-4 mA or x-y mA by programming x and y with a definition of 0.1 mA.
This function is suitable for use in applications with a signal other than 0-20 mA.

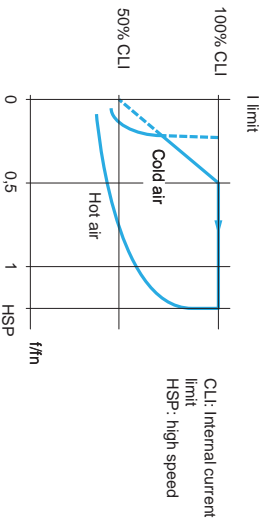

Adaptation of the current limit

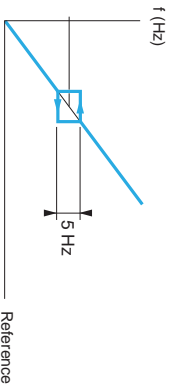

Motor speed change depending on the reference frequency with a skip frequency

Variable speed drives for asynchronous motors Altivar 38

Compatibility table for configurable I/O functions

b Configurable I/O

- Functions which are not listed in this table are fully compatible.
- ∨ Stop functions have priority over run commands.
- ∨ Speed references via logic command have priority over analog references.

The selection of functions is limited:
 - by the number of drive I/O which can be reassigned: if necessary, add an I/O extension card,
 - by the incompatibility of certain functions with one another.

Functions	d.c. injection braking	Summing inputs	PI regulator	+/- speed	Reference switching	Freewheel stop	Fast stop	Jog operation	Preset speeds	Speed regulation with tachogenerator or encoder
d.c. injection braking						A	A			
Summing inputs					↔					
PI regulator				↔				↔	↔	↔
+/- speed			↔		↔		A		↔	↔
Reference switching		↔		↔					↔	
Freewheel stop	X						X			
Fast stop						A				
Jog operation			↔	X					X	
Preset speeds			↔	↔	↔			A		
Speed regulation with tachogenerator or encoder			↔							

- ↔ Incompatible functions
- ↔ Compatible functions
- Not applicable

Priority functions (functions which cannot be active at the same time)

- X The arrow indicates which function has priority.
- A

Example: The "fast stop" function has priority over the "d.c. injection braking" function

Variable speed drives for asynchronous motors Altivar 38

Summary table of the configurable I/O assignments

Functions	Drive I/O		Without option card				With I/O extension cards			
	Relay R2	Analog input AI2	Analog output AO1	3 logic inputs LI2-LI3-LI4	2 logic inputs LI5-LI6	Analog input AI3	Logic/output LO	Analog output AO	Encoder inputs A-, A+, B-, B+	
Auto-tuning										
Reverse operation										
Alterrate ramp switching										
Jog operation										
+/- speed										
Preset speeds										
Reference switching										
External fault										
Freewheel stop										
Injection stop										
Fast stop										
Motor switching										
Forced local mode										
PI auto/man										
Fault reset										
General reset (inhibits all faults)										
Summing reference										
PI regulator										
2 nd speed reference										
Speed feedback										
PTC probes										
Downstream contactor control										
Frequency threshold reached										
High speed reached										
Frequency reference reached										
Current threshold reached										
Motor thermal threshold reached										
Drive thermal threshold reached										
Drive running										
Loss of 4-20 mA reference										
Motor current										
Motor frequency										
Ramp output (signed)										
PI function output										
Motor power										
Motor thermal state										
Drive thermal state										

Possible assignments

Schneider Electric Industries SAS

Headquarters

89, bd Franklin Roosevelt
F - 92500 Rueil-Malmaison
Cedex

ART. 037960

<http://www.schneider-electric.com>



VVDED202042EN

December 2002

efesotomasyon.com